



A message from **Projecta**

The projection screen market keeps evolving alongside the innovations that are happening with projectors. We see the market trend where more and more installations are equipped with high resolution projectors, and that is a development that we at Projecta have been supporting for years. Our message remains that every projector needs a projection surface that matches the projector. The high-resolution range of projection surfaces that we develop in-house under the HD Progressive name keeps expanding to make sure we can keep to our end of the promise, a quality projection surface that gets the most out of your projection and offers a surface on which every pixel has a place for optimal detail.

However, the projector market also moves to brighter projectors to be used in larger spaces. The Projecta Extensa is the projection screen we introduced last year for this trend, a tab-tensioned screen up to 6 meters wide, perfectly flat and with HD Progressive surfaces. Now it's time to take an even bigger step with the EyeletPro, a custom lace and grommet projection screen surface for larger stages dedicated to high resolution.

To help you understand everything you need to know to make a good choice in projection surfaces, we have expanded AV University with Projecta courses. Go check it out!



Jan **Mergen**
Vice-President
Sales & Marketing EMEA Commercial

Keep learning with **AV University**



Projecta courses are available on AV University for you and your partners! You can go log-in to AVU and check out 'Projection and Projection Screen Technology: The Essentials'! In this 75-minute course, we'll share the most important aspects necessary to make a well-educated choice if a room would need a projection solution, and if so – what surface and screen would be the best option. It will also take you through important topics as ambient light, contrast, 4K and more. The course is accredited 1.5 Renewal Units for CTS and CTS-D by Avixa.

AV University is home to Chief, Da-Lite, Middle Atlantic, Projecta and Vaddio training courses. All courses are free and many offer CTS Renewal Unit credits. Our wide variety of course options includes product certifications, installation tips & tricks, how-to videos, application specifics, general industry knowledge and much more. You can pick and choose the courses that interest you the most, on your own time, at your own pace.

Interested in learning more and becoming a pro? Go to AV University and start the course!

LegrandAV.com/AVU



New Products 2019

New products for 2018	1
Legrand AV	2
About Projecta	3
Manufacturing projection screens	4
Projecta Academy	6
Why you need a projection screen	6
Sizing a projection screen to the room	7
Defining image quality	8
Benefits of tab-tensioned surfaces	10
HD Progressive for high resolution	11
Selecting the right projection surface	12
When is a projection surface suitable for 4K and 8K projection?	14
Screen surfaces - high resolution	16
Screen surfaces - standard resolution	17
Easy Install mounting and connectivity	20
Pre-installation options	21
Custom solutions	22
PROJECTA	24
Ceiling Recessed Projection Screens	24
Wall and Ceiling Mounted Screens	30
Larger Installation Projection Screens	36
Fixed Frame Projection Screens	46
Dry Erase Projection Screens	54
Manual Wall and Ceiling Mounted Screens	56
Portable and Tripod Projection Screens	60
Accessories	62
DA-LITE	68
Large Venue Projection Screens	70
Fixed Frame Projection Screens	74
Rear Projection Screens	76
INDEX OF ALL CHARTS	79
Glossary	103

EyeletPro

A new range of custom lace and grommet screen surfaces with the EyeletPro. The EyeletPro offers the opportunity to order just the projection surface in exactly the required size. The borders of the projection material can be finished to match the requirements of the installation. Within the 5,5 cm black hemmed edge, customizable spacing is available up to 20 cm between the non-reflective eyelets for an even tensioning of the projection surface.

The custom EyeletPro surfaces can be ordered up a width of 11 meters wide and 4.88 meters in height. High resolution projection surfaces can now be installed in locations with large pre-existing frames or used in truss-based event installations.





Legrand is the global specialist in electrical and digital building infrastructures. Its comprehensive offering of solutions for commercial, industrial and residential markets makes it a benchmark for customers worldwide. In the AV space, Legrand offers an extended portfolio of branded audiovisual products including flat panel mounting solutions, projector mounts, projection screens, equipment racks, PTZ cameras and furniture for AV markets. Its innovative products are sold under the Chief, Da-Lite, Middle Atlantic, Projecta, Vaddio and Sanus brand names. All brands work together to provide a breadth of product, strength of longevity, and advantage of superior customer service and support.

CHIEF

Chief focuses on commercial AV flat panel and projector mounts. Home Theater, Workstation and Custom Display Solutions are also part of the Chief product offering. Known in the industry for high quality mounts with both Custom and Universal options, as well as an extensive accessories line, Chief is focused on professional installers worldwide.

DA-LITE

For over 100 years, Da-Lite has been designing, manufacturing and marketing the most comprehensive line of projection screens in the world. Today, we offer our widest selection ever of proprietary projection screen fabrics and materials in our history.



Since 1979, Middle Atlantic Products has manufactured exceptional support and protection products to mount integrated AV systems in Residential, Commercial, Broadcast, and Security applications. Our focus is to provide the foundation for amazing AV experiences through innovative solutions and exceptional service that solve our customers' AV integration and technology challenges.

PROJECTA

Projecta is Europe's leading manufacturer of high quality projection screens. We design, develop and build an extensive range of projection screens in the largest projection screen manufacturing facility in Europe, located in Weert, the Netherlands. Founded in 1952, we have over 65 years of experience, and over time we have grown to become your trusted source for projection screen solutions.

vaddio

Vaddio manufactures professional quality PTZ cameras, Pro AV solutions and a full suite of Unified Communication and Collaboration systems. Combining enterprise class performance and industry leading support, Vaddio products enhance any AV experience by elevating the science of communication.



Made in The Netherlands since 1952

Projecta projection screens have been manufactured from high quality materials in the Netherlands since 1952. The Projecta facility in Weert is the largest manufacturing facility for projection screens in Europe. We build our projection screens from start to finish, so we can monitor the quality in every step. Each product is individually checked by a Projecta employee. Projecta products are marked with a Personal Quality Check (PQC) sticker after they have been approved during final inspection. Projecta's products comply with the most stringent European quality and safety requirements. The Projecta products are CE-labelled and are built under ISO 9001:2000 certification.

Future focused technology and innovations

Projecta keeps track of what's going in the AV market and develops projection solutions that match current and future projector technologies. The engineering of the HD Progressive line of projection surfaces is a great example of this. The features of these projection surfaces are developed to match the specific requirements of high resolution projection, like preventing microscopic variances in the base material for pixel preservation. The Projecta Dry Erase Screens also matches the latest technology for projection with touch interaction and Ultra Short Throw projection.

World-class customer service and project support

The multi-lingual Projecta field and inside sales teams are trained to support your project. We can assist with making the right choice for a projection screen that matches the projector capabilities for the optimal end result. Our customer service team will reply quickly and accurately to your questions and quote requests every day. Use the extensive features of Milestone.com for product details and to track your orders.

Extensive and quick customisation

Projecta projection screens are built to order from start to finish in-house to ensure a high level of flexibility. When your order comes in, we almost instantly start the production of your projection screen, and customizing can be done just as quick. Because of this, we are able to design and manufacture custom projection screens to match every challenging project.

Environmental responsibility

Projecta projection screens are manufactured in Europe's only ISO 14001 projection screen factory. Environmental sustainability is a priority to our business and a commitment to the communities where we live and work. Projecta pursued and attained ISO 14001 certification to ensure that sustainability is a continuous part of the company's future. ISO 14001 is the international specification for an environmental conscious management system and helps to identify, prioritize and manage environmentally risk on a daily and continuous basis.

Almost every projection surfaces used in our projection screens complies with the standards of the Greenguard® Environmental Institute. The Greenguard® Indoor Air Quality Certification certified these projection surfaces for the Greenguard® Children and Schools program. The Greenguard Environmental Institute aims to protect human health and improve quality of life by enhancing indoor air quality and reducing people's exposure to chemicals and other pollutants.

Delivery consistency and quick lead-times

In Europe's largest projection screen facility the entire lay-out is designed to ensure a smooth and quick process of building your projection screen. Thanks to this continuous effort by our operations team, Projecta can manufacture the projection screens you order

From start **to finish**



[1] At the largest manufacturing facility for projection screens in Europe, we build our products from start to finish so we can monitor the quality in every step. At our metal workshop, we form raw metal as a sturdy casing for projection screens.

[2] Metal is folded into the right shape.

[3] In our powder coating department, a special textured coating is applied to prevent unwanted reflection.

[4] Projection surfaces are cut to the right size by our specialists.





[5]

[5] Borders and black drops are added to the projection surface with great attention.

[6] All components are combined and assembled. After assembly, factory settings are finalised to each product for the optimal result. Every product is then subjected to a series of checks and tests.

[7] Each product is individually checked by a Quality Engineer. Projecta products are marked with a Personal Quality Check (PQC) sticker after they have been approved during final inspection.

[8] High quality packaging is used to prepare the product for shipment and storage.



[6]



[7]



[8]

Why you need a projection screen

Projection screens are the final element in the chain of audio visual installation projects. They are necessary to achieve the highest quality projected image. Projection on another surface or material will give some sort of image, but it will never provide the bright and uniform reflection a projection screen guarantees. Our projection screens are available with a wide choice of projection surfaces.

Each projection surface has its own features that improve or retain the projected image to specifically deal with the various projection challenges. Projection surfaces have a reflective coating which will direct the projected light towards the audience and ensure an even distribution of light. This makes selecting the correct projection surface an essential part of planning an audio visual installation.



Projection screens in the current AV market

Flat panel displays are a popular choice in meeting rooms nowadays and have replaced many of the smaller sized projection screens. Projection screens however will offer a seamless viewing area in much larger sizes and that matters if it is important that the audience can see the required detail in the content. If you use the calculation of the next page, you will

see that in rooms deeper than 5 meters a flat panel display will be too small for the viewers in the back of the room. Besides meeting room applications, projection screen installations offer large to extremely large viewing areas for auditoriums, conference halls and special applications as simulation.

A projection screen ensures the following essential results:

A flat surface for image projection

A projection screen will give a flat and dedicated area for reflecting the projected image toward the audience without effecting the content. This is vital to achieve a focused and detailed projected image.

A large image size

With projection you can achieve very large sizes for very large audiences, and we produce projection screens to match the impressive capabilities of the most sophisticated projectors.

A uniform image

An even distribution of light on a projection screen is known as "good uniformity" in projection terminology. Uniformity is essential for an even image with a wide viewing angle in the desired direction.

Sizing a projection screen to the room

Choosing the correct projection screen is of great importance. The purpose of the projection screen is twofold: to display the visual information without loss of image quality and to direct the projected light towards the audience. Both requirements must be satisfied in order to ensure optimum perception of the projected image. If you want everyone in the room to see what is on the screen, make sure you use the right size projection screen.

This is necessary to ensure everyone can see the detail of the projection. The use of high resolution projectors in most applications creates quality images with great detail. This higher resolution also implies smaller font text and images which has its effect on the correct choice of projection screen size. The InfoComm International standard therefore recommends the following rules to determine the correct size of the projection screen:

16:10 WIDE and 16:9 HDTV aspect ratios

You can calculate the diagonal of the projection screen that will match your situation by dividing the room depth by two.

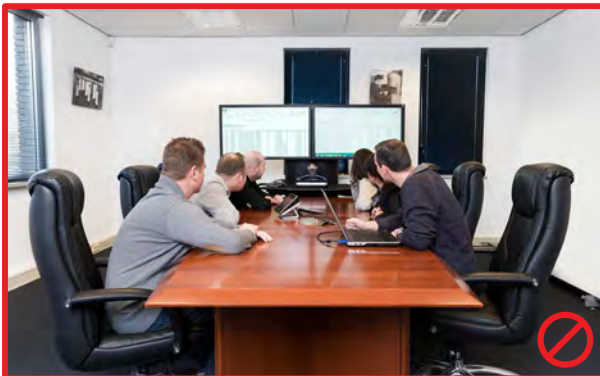
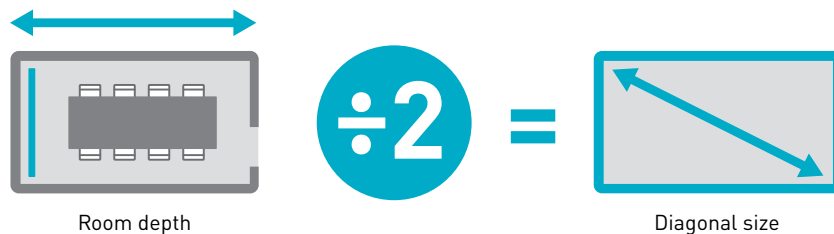

You should also consider:

Ceiling height

Take the ceiling height into account in your calculation as this is often a limiting factor.

Comfortable viewing height

For professional and educational applications the distance between the floor and the viewing area of a projection screen should be approximately 125 cm to make sure those sitting in the rear of the audience can see the projection. Depending on the height of the ceiling, this may require additional black drop if the projection screen is ceiling mounted. For home entertainment applications this distance should be between 60 and 90 cm.

Comfortable viewing distance

For professional and educational applications the first row of seats should be approximately 1.5 screen heights away. For home entertainment applications the first row of seats should be approximately 2 screen heights away.

Always consider the most demanding usage of your projection when determining the size although a flat panel display may seem a good option for a smaller size presentation area, in most cases these are actually too small. If the rules of thumb are applied often a larger projection screen should be specified to make sure the audience can see the necessary level of detail comfortably.

Defining **image quality**

The ultimate purpose of a projection screen is to ensure that the quality of the projected image is reflected toward the audience while maintaining or even improving the projection in brightness or contrast. There are several factors which determine the

perceived quality and which should be taken into account when selecting a particular projection screen and projection surface. All these factors play an important role and need to be tuned to each other to create the optimum projection.



Ambient Light

Ambient light is the amount of unwanted light in a room that can affect the projection in a negative way. Ambient light can come from windows or from room lighting. Ambient light on a projection screen causes a less bright image. This can be countered by using window blinds to darken the room, using a projector with a stronger light output or using a projection surface with a higher gain. However, a higher projector output will only give a boost to the white levels in your projection, while ambient light washes out the black levels and brings down the necessary contrast needed to see detail. An Ambient Light Rejecting projection material physically blocks the effect of ambient light on a projection surface while enhancing the contrast of the projected light. Such a projection solution allows projection installations in environments where before projection was not an option.

Projector Characteristics

Output (ANSI-lumen)

The brightness of a projector is measured in ANSI-Lumen. The higher the number of ANSI-Lumen, the brighter the projected image and the more it can compensate for ambient light. Please note that a too bright image is not pleasant to look at for a longer period of time.

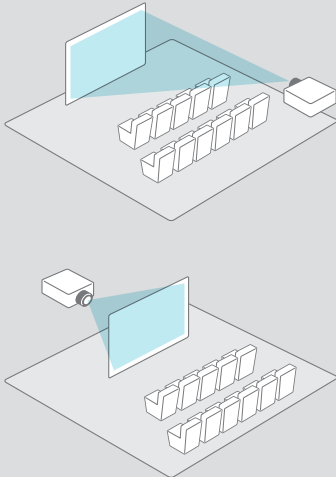

Projector position

A projector can be placed in front of or behind a projection screen. The projector can also be mounted on the ceiling or placed at table height. A projection surface has a specifically designed coating that handles the light that hits it, which makes it necessary to pay attention to your choice of projection surface type.

Lens-type

The specific lens of a projector determines the distance between the projector and the projection screen, which is the throw distance. If a short throw or ultra short throw lens is being used it is important to use a tensioned projection surface. Using a short throw or ultra short throw lens decreases the distance between the projector and the projection screen. This however also creates a situation where the projected light reaches the projection surface at an extreme angle, which is why we recommend using a tensioned projection surface to avoid distortion of the image.



Gain

Gain is a measure of reflection performance. Gain is related to a universal reference standard: Magnesium Carbonate ($MgCO_3$). Rather than absorbing light, $MgCO_3$ reflects projected light back with perfect evenness. Matte White, with a measured gain of 1.0, is the standard brightness for a projection screen surface.

LUX

The perceived amount of light that is reflected by the projection screen is expressed in LUX. The optimum image quality and readability is achieved when the projector's light output, the size of the projection screen and the gain characteristic of the screen surface are all appropriately matched to each other.

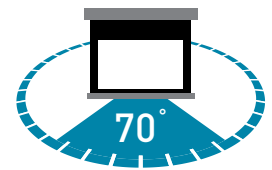
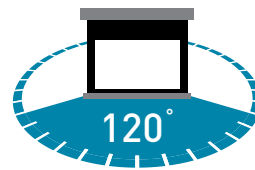
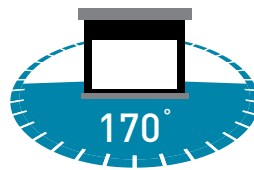

Viewing Angle

The viewing angle of a projection screen surface indicates the maximum angle at which the projected image is still clearly visible. The brightness of the image decreases as the viewing angle increases in relation to the axis of the image. The maximum viewing angle is the point at which the viewer perceives less than 50% of the luminous intensity of the image. This limit is the commonly accepted standard for image quality.



Borders

Black borders surrounding the projection area on a projection surface increase the perceived contrast of the projected image. Because Projecta's objective is to satisfy the highest display image quality standards, all of our projection screens are supplied with black borders where this is technically feasible. Another benefit of borders on a projection screen is to facilitate projector alignment.

Screen flatness

affects the resolution in your projection

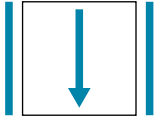

Non-tensioned screens are only supported vertically, potentially causing waves or ripples in the projected image.

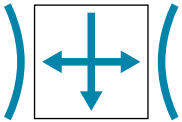

Tensioned screens are supported both vertically and horizontally, creating a uniformly flat projected image.

The benefits of using a tensioned projection surface:

Always a guaranteed flat projection surface

The tab-tensioning system will keep the projection surface under a constant tensioning for a perfectly flat viewing area. A flat projection surface will get the most out of your projector, making sure no pixels get lost or deformed. If detail is important a perfectly flat projection area is vital.

A smoother surface

Non-tensioned fiberglass surfaces have a visible coarse texture that creates noise in the projected image and greatly reduces the image quality. The vinyl projection surfaces used in tab-tensioned projection screens are smoother and preserve the image quality much better making it suitable for high resolution projectors.

A longer life cycle

Changes in temperature and humidity

A tensioned projection surface can withstand changes in temperature and humidity better than a non-tensioned surface.

Resilience

The resilience of the tensioned materials will result in an even longer life cycle of the product.

With HD resolution especially, only a tensioned screen should be specified. A tensioned screen will show the flattest and most pleasing image quality from a projector. Fiberglass surfaces are non-tensioned materials used for basic manual and electric type screens and cannot reproduce an HD quality resolution because the material is only tensioned vertically, potentially elongating and warping individual pixels in the projected image.

Additional features:

Slim-Tabs

A lower profile, stronger tab design to keep the screen perfectly tensioned.

Tensioning mechanism

On the slat bar a preset adjustable mechanism is available to adjust screen tensioning.



HD Progressive

for high resolution



HD PROGRESSIVE

Every projected image will look better
on an **HD Progressive** surface

Color fidelity – Image uniformity – Pixel preservation
The best surface for HD, 4K and Ultra HD projection

HD Progressive Screen Surfaces

The chemical formula for our HD Progressive line of projection surfaces is designed to perfectly reflect and preserve the image being projected.

As projection advances the surface becomes more important. We research the science of surface with an in-house team of dedicated chemists. By studying the physics of light and experimenting with the science of surface we've discovered a better way. Behind each surface is a proprietary, environmentally friendly chemical formula. This means there is a better surface for your image.

Color Fidelity

We hold ourselves to the highest standard when it comes to color fidelity. All of our surfaces are individually tested and color measured to ensure each surface will preserve the true color of the projector.



Image Uniformity

It is imperative that the surface reflects light in a manner that maintains the uniformity of the image being projected. HD Progressive ensures an even distribution of projected light for a perfect image.



Surface Granularity

The clarity of an image is in the microscopic details. Our vinyl technology ensures a premium surface, free of microscopic dips or grooves, so that every pixel is preserved.



When you look closely at a projection screen surface, many surfaces look like varying grains of sandpaper and others have microscopic variations on the surface. This causes pixel loss and "noise" in the image because the surface isn't able to perfectly reflect the projected image. As projection resolution advances, pixel preservation becomes much more important to preserve the clarity of your image.

The chemistry behind a HD Progressive surface is formulated to create a surface free of microscopic variances allowing the screen to essentially disappear. The result is brilliant light, vibrant color and the best surface for HD, 4K and Ultra HD projection.

HD Progressive surfaces are available in:

Tensioned DescenderPro 26

Tensioned Elpro Large Electrol 42

Tensioned Elpro Concept 32

HomeScreen Deluxe 50

Extensa 39

FullVision 51

Tensioned Descender Large Electrol 40

EyeletPro 53

Selecting the right projection surface

Make sure all components and variables of the entire installation are tuned to each other to create an end result the audience can comfortably watch with the necessary detail. Follow these steps to ensure your

projection has the right size, the right brightness and has a projection surface capable of the quality of the used projector.

1. Match projector and resolution

Check the resolution of the projector you are planning to use and match this with a range of projection surfaces. Not every projection surface is capable of maintaining the quality of a projector.

Resolution	Pixels	Aspect ratio	Suggested projection surface		Front projection		Rear projection
XGA	1024 x 768	4:3	Fiberglass	Standard Resolution	Matte White High Contrast Datalux	- color neutral - additional contrast - additional reflectivity	Retrotex
HD 720p	1280 x 720	16:9					
WXGA	1280 x 800	16:10					
WXGA+	1440 x 900	16:10	Vinyl (tensioned)	Standard Resolution	Matte White	- color neutral	Dual Vision Ultra Wide Angle
HD+	1600 x 900	16:9					
WSXGA+	1680 x 1050	16:10					
HD 1080p	1920 x 1080	16:9	Vinyl (tensioned)	High Resolution recommended	HD Progressive		Dual Vision Ultra Wide Angle
WUXGA	1920 x 1200	16:10					
WQHD (2K)	2560 x 1440	16:9	Vinyl (tensioned)	High Resolution necessary	HD Progressive		Dual Vision Ultra Wide Angle
WQXGA (2K)	2560 x 1600	16:10					
4K	4096 x 2160	Custom					

Please note: Projecta strongly advises to always select a tensioned projection surface or Dry Erase Screen when an ultra short throw lens is used, to avoid image distortion caused by the extreme angle.

2. Determine the size of your projection screen

Make sure a size of screen is used that allows everyone in the room to comfortably read what is on the screen. You can calculate the diagonal of the projection screen that will match your situation by dividing the room depth by two. This calculation can be used for 16:10 and 16:9 aspect ratios.

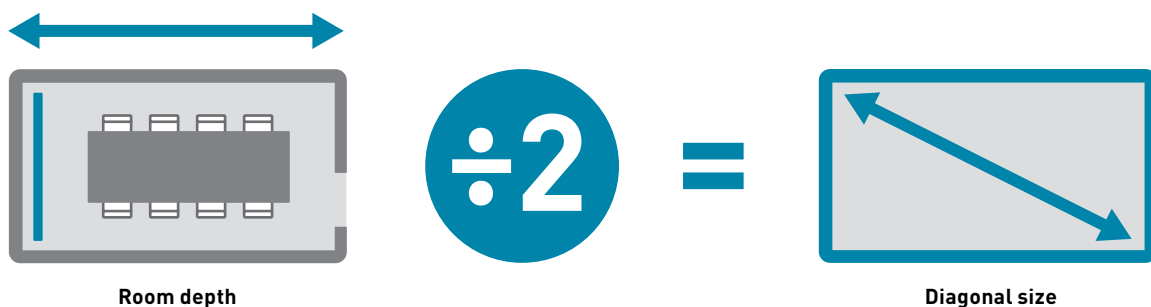

3. Make sure your projection is bright enough

Use the LUX formula to determine if your projection will be bright enough for the room conditions. The brightness on the screen is influenced by the projector output (ANSI-Lumen), size of the projected area and the chosen screen gain.

LUX calculation

$$\text{LUX} = \frac{\text{Projector ANSI Lumen}}{\text{Screen surface area in m}^2} \times \text{gain}$$

Brightness scale

Room conditions	LUX
all lights and windows	1100
all lights	850
most lights	650
dim lights	450
dark	200

Please note: To avoid the chance of speckling with laser projection, we recommend a projection surface with a gain below 1.0 - make sure the size and output of the projector accommodate this lower gain to reach the required brightness.



Example

Room: Most lights on during projection

Projector: 4000 Lumen

Screen size: 193 x 310 cm (5.98 m²)

Screen Surface: HD Progressive 0.9

Calculation

$$\frac{4000 \text{ ANSI Lumen}}{5.98 \text{ m}^2} \times 0.9 = 602 \text{ LUX}$$

Recommended solution

For a room with most lights on we recommend an outcome of at least 650 LUX. The result of this situation will not be bright enough for the room conditions. Update your installation by making one of these changes:

- higher output projector
- smaller screen size
- **higher gain screen**

HD Progressive 1.1



$$\frac{4000 \text{ ANSI Lumen}}{5.98 \text{ m}^2} \times 1.1 = 735 \text{ LUX}$$

4. Consider the contrast in your projection

Ambient Light Rejection - Too much light in a room will interfere with the projected light and decrease the contrast in the image.

A projector cannot project 'black' and because of this, the darkest parts in the projection is created by shadows or the lack of light. If there is a lot of ambient light in a room, this shadow will be brighter and visually closer to the brightest white in the projection, decreasing contrast and detail. This situation cannot be solved by a brighter projector or a higher gain screen material, but only by using a projection surface that blocks the unwanted light and only accepts the projected light - Parallax.

Parallax is a projection technology that features an advanced optical lens system that rejects light. Parallax is made up of multiple micro-layers to achieve light blocking properties and superior viewing angles.



PARALLAX



When is a projection surface **suitable for 4K and 8K** projection?

Here's something to think about - using a material that is not suitable for 4K projection will cause a distorted image and pixel loss. When you are planning a project that has 4K projection, it is vital to consider the projection material to use and here is why.

A 4K image has a very high pixel density with 4096 pixels horizontally and 2160 vertically. The size of a pixel has become so small that the texture of a projection material will have an actual effect on what the viewer is seeing as a result. Have you ever felt the projection surface of a projection screen? If it was non-tensioned, it likely was a fiberglass or woven material that feels like coarse sandpaper. This was never an issue with older, lower-resolution projectors, as the pixels were big enough to cover these bumps and dips. With current projectors, the resolution uses smaller pixels, which can get deformed or lost in the structure of the surface. These bumps and grooves on projection materials cause pixels to be distorted or lost and have an effect on the image quality and visible detail on a larger scale.

Let's take a look at popular projection materials and see if they are suitable for high resolution projection.

	<p>WOVEN MATERIAL</p> <p>As a woven material is very coarse and uneven, every pixel will be distorted.</p> <p>NOT SUITABLE FOR 4K PROJECTION</p>	<p>Projected image</p> <p>PIXEL 1 PIXEL 2 PIXEL 3 PIXEL 4</p> <p>Pixel distortion</p>
	<p>FIBERGLASS</p> <p>As a fiberglass based material has clearly visible texture, every other pixel will be distorted or lost.</p> <p>NOT SUITABLE FOR 4K PROJECTION</p>	<p>Projected image</p> <p>PIXEL 1 PIXEL 2 PIXEL 3 PIXEL 4</p> <p>Pixel distortion</p>
	<p>HD PROGRESSIVE</p> <p>HD Progressive has the smoothest surface on the market. It's free of microscopic dips or grooves to retain all vital projection capabilities. On such a smooth surface, even the tiny pixels of 4K or 8K projection will remain visible and no detail is lost.</p>	<p>Projected image</p> <p>PIXEL 1 PIXEL 2 PIXEL 3 PIXEL 4</p> <p>No pixel distortion</p>

For 4K projection, or any other high resolution projection, a surface is needed that is as smooth as possible to avoid pixel distortion and the very best image quality. If you invest in a projector that is capable of great detail, you do not want the projection surface to degrade the image quality. HD Progressive is the only option for high-resolution projectors and actually makes every pixel count.

Getting the very best image quality

The goal of any project that has a 4K projector is obviously to get fantastic image quality. Besides preserving pixels for the best detail, there are other important aspects to get the very best result – uniformity and color fidelity.



Color fidelity

Every material you project on will have some sort of color-shift, which will change the color that is carefully formed in the engine of the projector to a slightly different tint. A standard Matte White material will, for instance, shift the color slightly toward blue. The chemistry behind an HD progressive projection coating is formulated to reproduce exact colors in projection. All of our HD Progressive surfaces are individually tested and color measured to ensure each surface will preserve the true color of the projector.



Uniformity

A very important part of projection is uniformity, or how evenly the light is spread over the image. If the light is not evenly dispersed over the entire surface, but bundled in the center, information in the corners can be dim and hard to see or read. This is a common issue with higher gain surfaces or when poor projection materials are used. HD Progressive ensures an even distribution of projected light for a perfect image and unrivalled uniformity. The even light distribution within the image may even make it hard to notice that you are watching a projected image. With HD Progressive you get great uniformity. The projected light will look evenly bright on any space of the projection screen to create a well-illuminated and detailed image for the audience.

Projection screen size and 4K/ UHD

A true 4K resolution has a pixel ratio of 4096 horizontal and 2160 pixels vertical (approximately a 1.9:1 aspect ratio). Ultra HD (UHD) is a resolution of 3840 pixels horizontal and 2160 pixels vertical with an exact 16:9 aspect ratio and is often used in televisions and displays. Many suppliers market their UHD products as 4K and this can create confusion. So keep in mind that a custom screen size in 4K ratio is needed for the projected image to perfectly fit the projection screen.

4K

UHD / 16:9



HD Progressive

projection surfaces

HD PROGRESSIVE

The chemistry behind a HD Progressive surface is formulated to create a surface free of microscopic variances allowing the screen to essentially disappear. The result is brilliant light, vibrant color and the best surface for HD, 4K and Ultra HD projection.

Tensioned Projection Surfaces for High Resolution Front Projection



Gain: 0.6
Viewing Angle: 170°

HD Progressive 0.6

Ideal for high output projectors or applications where projector brightness and screen size require low gain, the gray surface compensates for a brightly lit environment so that image contrast is preserved. In low ambient light, HD Progressive 0.6 provides deep contrast for a rich enhanced image, and is typically used with video. Seamless in any width up to 488 cm in height.



Gain: 1.1
Viewing angle: 170°

HD Progressive 1.1

Ideal for applications where projector brightness and screen size require an increase in gain, the white surface offers true color reproduction and fidelity. Seamless in any width up to 488 cm in height.



Gain: 0.9
Viewing Angle: 170°

HD Progressive 0.9

Ideal for moderate to high output projectors, the light gray surface achieves a perfect balance between color reproduction and image contrast. Seamless in any width up to 488 cm in height.



Gain: 1.3
Viewing Angle: 150°

HD Progressive 1.3

Ideal for applications where projector brightness and screen size require an increase in gain, the purest white HD Progressive surface offers true color reproduction, and allows for more flexibility with ambient light conditions. It also allows for easy viewing of detail in video as well as charts and graphs in a corporate setting. Seamless in any width up to 488 cm in height.



Gain: 1.1
Viewing Angle: 120°

HD Progressive 1.1 Contrast

HD Progressive 1.1 Contrast provides a deeper reproduction of black, which improves contrast, and an increased reflectivity to enhance brightness for moderate ambient light. Ideal for video images, HD Progressive 1.1 Contrast is 16K-ready. Seamless in any width up to 488 cm in height.

Tensioned Flexible Projection Surfaces for High Resolution Rear Projection

These rear projection surfaces are tensioned on four sides to attain a perfectly flat surface and used in projection screens in which the material is tensioned.



Dual Vision

Dual Vision is a flexible vinyl surface ideal for rear projection, but capable of both front and rear projection. Dual Vision is ideal for video projection under controlled ambient light conditions. With an exceptionally wide viewing angle and light gray tint, a sharp image with no color shift is observed regardless of location in the room. Seamless in any width up to 488 cm in height.



Ultra Wide Angle

Ultra Wide Angle is a flexible vinyl rear projection surface designed for wide viewing angles with controlled ambient light. It is ideal for installations using multiple projection edge blending or wide format screens with short focal length projection lenses. Ultra Wide Angle dramatically reduces the potential of hot spotting. Seamless in any width up to 488 cm in height.

Tensioned Flexible Projection Surfaces for Standard Resolution Front Projection

These projection surfaces are tensioned on four sides to attain a perfectly flat surface and used in projection screens in which the material is tensioned.



Matte White (tensioned)

Tensioned Matte White is a unity gain vinyl surface with a smoother surface than non-tensioned Matte White. It features a white surface for good color reproduction for environments with controllable ambient light. Seamless in any width up to 488 cm in height.

Special Projection Surfaces for Standard Resolution Front Projection



HD Progressive 1.1 Contrast Perf

HD Progressive 1.1 Contrast provides a deeper reproduction of black, which improves contrast, and an increased reflectivity to enhance brightness for moderate ambient light. The perforated vinyl surface allows for the installation of speakers behind the surface. Available in any width up to 240 cm in height.



Matte White Sound

Designed for applications where a more realistic soundstage is desired, this surface allows for speakers to be placed behind the screen. With virtually no sound loss and good image quality, this surface provides the same optical characteristics as the Matte White surface with special perforations to allow sound to pass through the screen material. This is a vinyl-based surface.

Non-Tensioned Projection Surfaces for Standard Resolution Front Projection

These projection surfaces are supported and used in non-tensioned projection screens.



Matte White

Matte White is a fiberglass surface for non high-definition projection and environments with controllable ambient light that preserves color as well as black and white images. Seamless sizes vary by product.



High Contrast

High Contrast is a fiberglass surface with a gray base for deeper reproductions of black, which improves contrast. It is for non high-definition projection and environments with moderate ambient light. Available in any width up to 300 cm in height.



Datalux

Datalux is a fiberglass surface with a reflective coating for lower output non high-definition projectors. It offers increased brightness with a reduced viewing angle. Suitable for uncontrolled ambient light. Available in any width up to 240 cm in height.

Non-Tensioned Projection Surfaces for Standard Resolution Rear Projection

These projection surfaces are used in non-tensioned projection screens.



Retrotex

A neutral grey vinyl rear projection screen that provides contrast enhancement. A versatile rear projection surface, Retrotex is a good choice for applications with good control over ambient light. This is a vinyl based surface.

Use the following guide to determine the best screen surface option for your installation

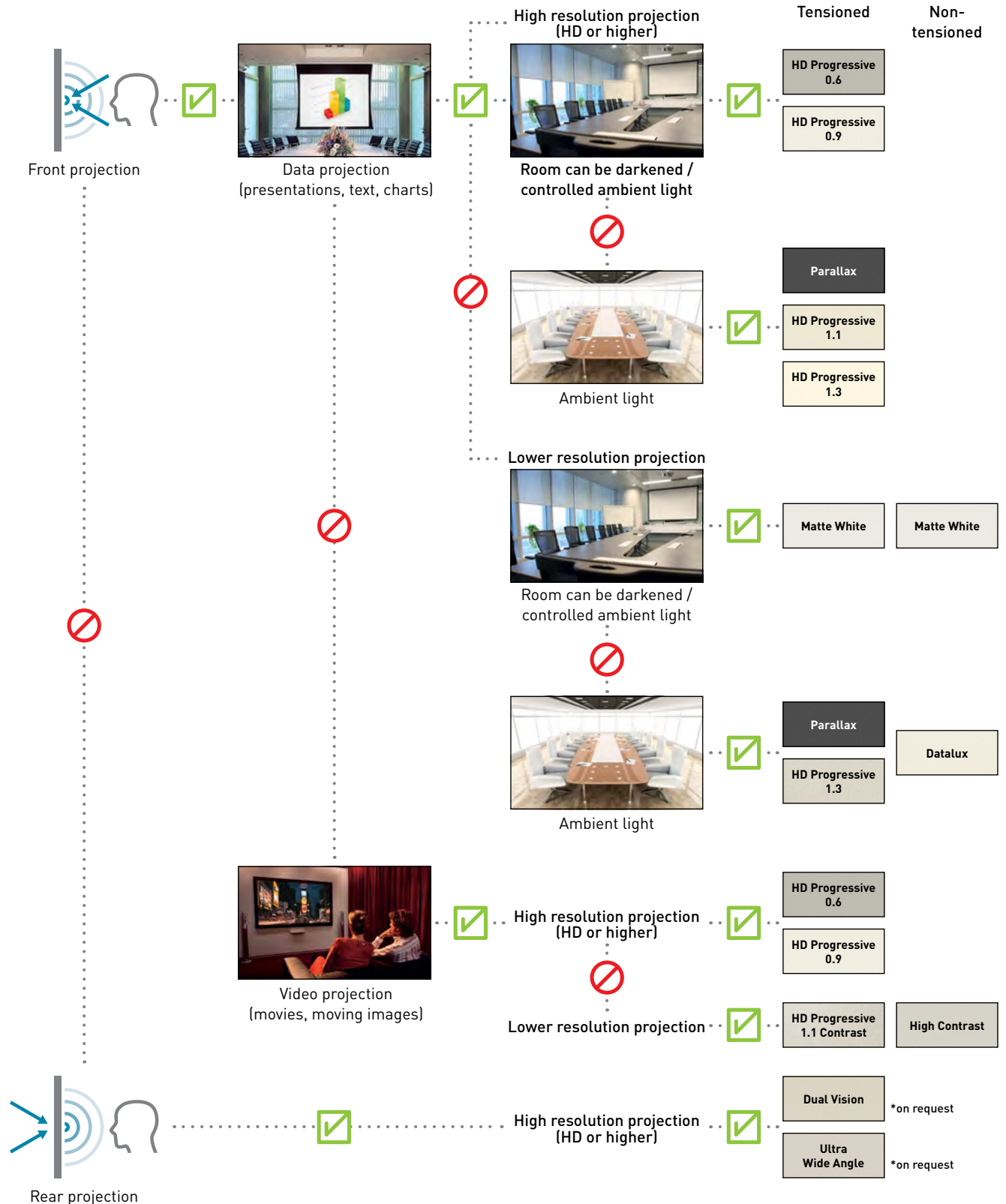

Please note: Projecta strongly advises to always select a tensioned projection surface when a short throw or ultra short throw lens is used to avoid image distortion.



Easy Install Mounting and **Connectivity**

Installing a projection screen was never as easy as it is with Easy Install. Save time and money with the unparalleled ease of mounting the projection screen and connecting it to a power source or accessory.

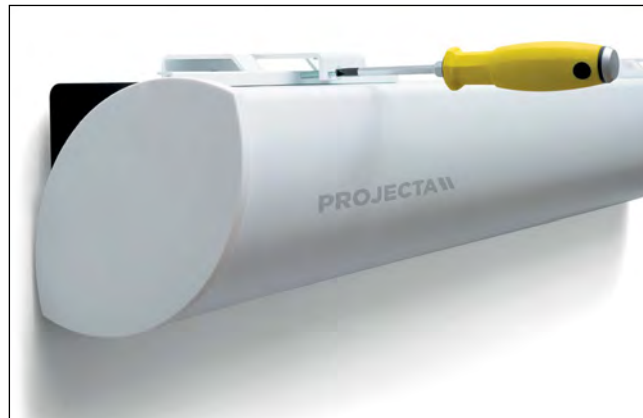

Easy Install **Mounting**

With Easy Install, begin by positioning the two brackets on a wall or ceiling. The brackets may be positioned within 50 cm of either end of the casing. This flexibility in installation gives the option to select the best and strongest position for the brackets. When the brackets are fixed to the wall or ceiling the projection screen is easily 'clicked' into the brackets. A screw secures the screen to each bracket finishing a quick and safe installation.



Easy Install **Connectivity**

The end cap on the left-hand side of the screen is easily removable, providing access to the Easy Install plug. This plug can be connected to the supplied power cord offering a quick and safe electrical connection. This plug-and-play system can also be used to connect the Easy Install accessories for control and operation. With the Easy Install accessories, a motorised projection screen can be wired for any method of operation or connected to a control system.



Easy **Serviceability**

Accessing a projection screen to make adjustments and complete maintenance has been made installer friendly by Projecta. The motor and screen surface remain accessible even when the projection screen is installed in a ceiling. The bottom panel can be lowered and remains connected to the casing by two steel cables.

Pre-Installation options

The Projecta ceiling recessed solutions offer a unique opportunity to pre-install the case of the projection screen with the 2-step installation.

During the construction of a building or refurbishing of a room, the case of the Projecta DescenderPro series can be installed separately of the actual projection screen section. By doing so, the ceiling can be finished and does not need to be opened later to build-in the case at a later stage. Furthermore damage is prevented to the projection surface and motor during the rough stages of construction. When the construction is finished the rest of the projection screen, containing the bottom panel with the roller, screen fabric and motor can be installed easily.

This is how it works:

Install the Screen Case in the ceiling

Create space in the ceiling for the screen case according to the measurements in the instructions. Push in the case and the flanges on the case will hide the rough edges of the cut-out. Connect power to the cable on the left side of the case where a pre-installed cable is positioned.

"Click" in the Screen Surface Assembly

When the construction is finished, take the Screen Surface Assembly out of the box. The Screen Surface Assembly includes the roller, the motor and the screen surface. This assembly can be installed direct in the Screen Case in the ceiling by clicking it in place with the new easy connectors on either side.

Connect electricity

Connect the Projecta Easy Install connector from the Screen Surface Assembly to the connector already in place at the left side of the casing. This connector can also be used to connect various accessories.



Install the bottom panel

Take the bottom panel out of the box and lock it in place. Now you can finish the installation by attaching the the end- flanges left and right for a clean appearance.

To facilitate the Projecta 2-step installation the Case and Screen Surface Assembly can be ordered separately.





Shorten the case and shorten or reduce the width of the projection screen surface.

Paint the case, slat bar and plastic components in a different RAL colour.
When the screen needs to match a specific colour scheme, Projecta can paint the case in any colour specified.

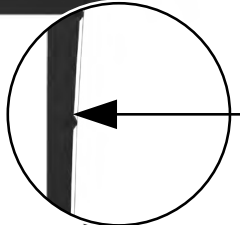

Shorten or reduce the width of the projection screen surface.

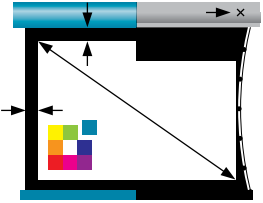

Customise this projection screen to perfectly fit your installation

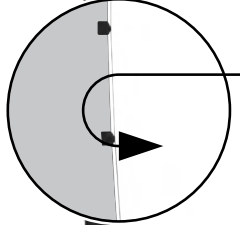

Reverse installation of the surface so that the projection side is located to the rear.
Specify this method when the projection screen surface needs to exit the case reversely because the normal screen path is obstructed by an obstacle or because the case is to be mounted to a beam.

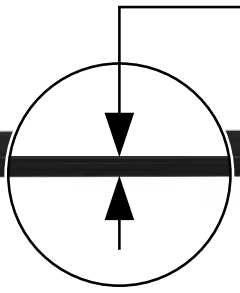

Projection screen without black borders.

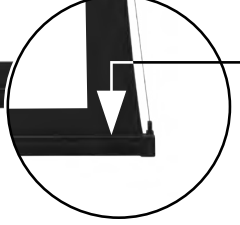

Extension of the projection screen surface.
If required and technically feasible, Projecta installs a longer projection surface in the case.

Applied customization: Tensioned Elpro Concept Width: 220 cm Extended black drop: 45 cm Customized case color





Applied customization: Tensioned Descender Large Electrol Width: 450 cm Extended black drop: 20 cm

Silent motor

Specify the Silent Motor option when an extra silent operation of the electric projection screen is required.

Available for:

- Tensioned DescenderPro
- DescenderPro
- Tensioned Elpro Concept
- Elpro Concept

Extension of the projection screen surface with additional black drop.

When the projection screen surface needs to be extended and a larger black border is required at the top or bottom, we adapt the surface to your specifications.

Shortened frame and projection screen fabric for fixed frame screens.

We can also modify the frame and projection screen surface of our fixed frame range to suit the installation needs.

Paint the frame of a fixed frame screen in a different RAL colour.

We can also paint the frame of a fixed frame screen in any colour specified.

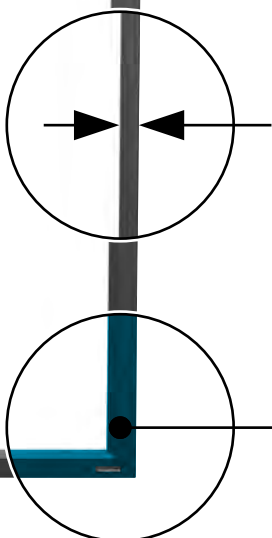
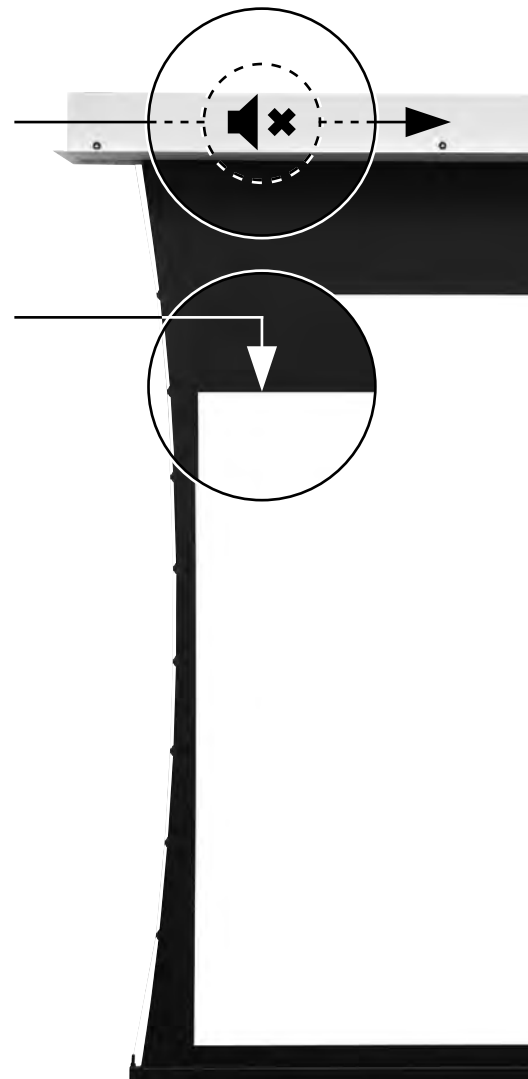

Ceiling Recessed Projection Screens



Product: Tensioned Descender Electrol Installer: Hecla Professional Audio & Video Systems Location: TU Delft (The Netherlands)



26

Tensioned
DescenderPro



28









DescenderPro



HD PROGRESSIVE



16:10 16:9

 HD Progressive 0.6 Viewing Angle: 170° Gain: 0.6	 HD Progressive 1.1 Contrast Perf Viewing Angle: 120° Gain: 1.1
 HD Progressive 0.9 Viewing Angle: 170° Gain: 0.9	 Matte White Viewing Angle: 120° Gain: 1.0
 HD Progressive 1.1 Viewing Angle: 170° Gain: 1.1	 Dual Vision Viewing Angle: 130° Gain: 0.9
 HD Progressive 1.3 Viewing Angle: 150° Gain: 1.3	 Parallax 0.8 Viewing Angle: 170° Gain: 0.8
 HD Progressive 1.1 Contrast Viewing Angle: 120° Gain: 1.1	

Tensioned **DescenderPro**

- The most comprehensive ceiling recessed projection screen in the market with tab-tensioned system for a perfectly flat screen surface. Redesigned and improved for ease of installation and a clean finish.
- Easy Serviceability System – the roller with motor and screen surface can be ‘clicked’ in-place for easy installation and servicing. Once installed, the motor and screen surface remain accessible.
- After installation, the closure panel and side-caps align for a clean finish without gaps.
- Choose between the unique 2-step installation or use direct 1-step installation-option.
- The tab-tensioning system will keep the projection surface under a constant tensioning for a perfectly flat viewing area.
- The case and the projection screen surface can be made to exactly the right size and the case is available in any colour for optimal integration into any interior.
- The Tensioned DescenderPro is supplied with a wall switch.
- The projection surface is extremely flat, making it suitable for all types of data and video projection.
- A five-year limited warranty on the Descender range to match the high quality of the products.

Available dimensions

Minimum width: 180 cm |
Maximum width: | 400 cm

Other options

- Radio frequency: Includes built-in radio frequency receiver, making it possible to operate the screen using the supplied remote control.

Accessories

- All-in-One Control Box
- More on page 62



New case design for a clean finish

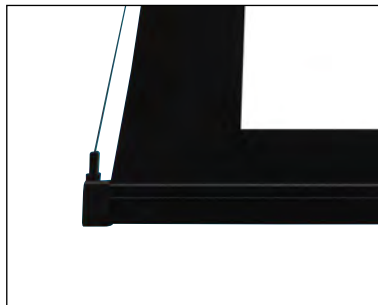

Slat bar retracts into the case



Now available with Parallax Ambient Light Rejecting option

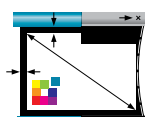

Customise this projection screen to perfectly fit your installation

SUITABLE FOR **ULTRA SHORT THROW PROJECTION** 

Dimensions and product codes on

84

Ambient Light Rejection goes Electric

Parallax 0.8 ALR is now available in the Tensioned Elpro Concept and Tensioned DescenderPro. Parallax is a projection technology that features an advanced optical lens system that rejects light, rather than only diffusing light. Up till now, this ALR material was only available in a fixed frame projection screen, but now it can also be selected as a surface option in the two most popular motorized screens.

Premium Ambient Light-Rejecting Technology

For environments with uncontrolled ambient light, there's no better solution than Parallax. Our industry-leading surfaces are made of lens-like micro layers designed to achieve optimal ambient light rejection. The result is a bright, speckle-free image without glare.

Parallax 0.8 surface for standard throw projectors (1.5:1 or greater) comes with a standard black drop of 5 cm.

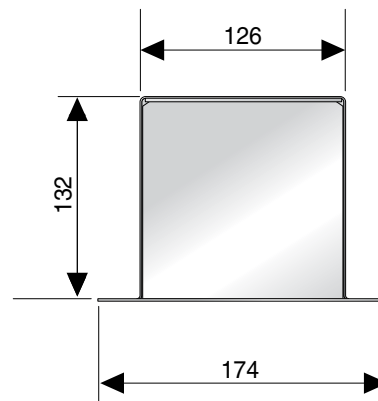



PARALLAX

Product: Tensioned Descender Electrol Installer: Barco Location: Kjaernes Gaard conference center (Moss, Norway)





16:10 16:9 4:3

-  **Matte White**
Viewing Angle: 120°
Gain: 1.0
-  **High Contrast**
Viewing Angle: 100°
Gain: 1.1
-  **Datalux**
Viewing Angle: 70°
Gain: 1.5

DescenderPro

- The most comprehensive ceiling recessed projection screen in the market. Redesigned and improved for ease of installation and a clean finish.
- Easy Serviceability System – the roller with motor and screen surface can be ‘clicked’ in-place for easy installation and servicing. Once installed, the motor and screen surface remain accessible.
- After installation, the closure panel and side-caps align for a clean finish without gaps.
- Choose between the unique 2-step installation or use direct 1-step installation-option.
- The case and the projection screen surface can be made to exactly the right size and the case is available in any colour for optimal integration into any interior.
- The DescenderPro is supplied with a wall switch.
- A five-year limited warranty on the Descender range to match the high quality of the products.

Available dimensions

Minimum width: 180 cm |
Maximum width: | 400 cm

Other options

- Radio frequency: Includes built-in radio frequency receiver, making it possible to operate the screen using the supplied remote control.
- Without borders

Accessories

- All-in-One Control Box
- More on page 62



Triangular slat bar retracts into the case



New case design for a clean finish

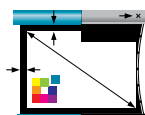

Customise this projection screen to perfectly fit your installation

NOT SUITABLE FOR
ULTRA SHORT THROW
PROJECTION 

Dimensions and product codes on

2-Step installation

Screen Case / Screen Surface Assembly

- Order the screen case separate from the screen surface. Install the Screen Case during the rough-in stages and the Screen Surface Assembly at a later stage preventing any damage.
- The Screen Surface Assembly includes the roller, the motor and the screen surface.
- This assembly can be installed direct in the Screen Case in the ceiling by clicking it in place with the new easy connectors on either side. For servicing it is just as easy to remove the entire Screen Surface Assembly.
- Order the case first and decide the aspect ratio and screen surface at a later stage ensuring optimal flexibility.

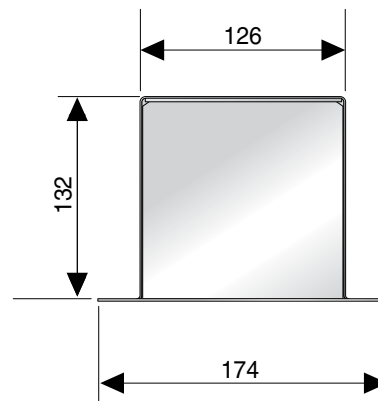

Product: Descender Installer: AP Media s.r.o. Location: Austria Trend Hotel (Bratislava, Slovakia)



Wall and Ceiling Mounted Screens



Product: Tensioned Elpro Concept Installer: Videlio Rennes Location: b<>com l'Espace Conférences (Rennes, France)

© Fred Pieau



Tensioned
Elpro Concept



Elpro Concept



Compact **Electrol**



16:10	16:9	2.35:1	4:3
-------	------	--------	-----

	HD Progressive 0.6 Viewing Angle: 170° Gain: 0.6		HD Progressive 1.1 Contrast Perf Viewing Angle: 120° Gain: 1.1
	HD Progressive 0.9 Viewing Angle: 170° Gain: 0.9		Matte White Viewing Angle: 120° Gain: 1.0
	HD Progressive 1.1 Viewing Angle: 170° Gain: 1.1		Dual Vision Viewing Angle: 130° Gain: 0.9
	HD Progressive 1.3 Viewing Angle: 150° Gain: 1.3		Parallax 0.8 Viewing Angle: 170° Gain: 0.8
	HD Progressive 1.1 Contrast Viewing Angle: 120° Gain: 1.1		

Tensioned Elpro Concept

- Stylishly designed electric projection screen for wall or ceiling mounting with tab-tensioned system for a perfectly flat screen surface. If you cannot hide the case into the ceiling, use a projection screen that is worth noticing.
- A five year limited warranty on the Concept range to match the high quality of the products.
- Now available with Parallax 0.8 ALR surface for standard throw projectors (1.5:1 or greater). This materials comes with a standard black drop of 5 cm.
- Easy to mount onto a wall or ceiling thanks to the Easy Install system.
- Thanks to Easy Install plug and play connecting the screen to power or one of the many accessories is quick and easy.
- The case and the projection screen surface can be made to exactly the right size and the case is available in any colour for optimal integration into any interior.
- Limit switches are factory set guaranteeing a long life span. The Tensioned Elpro Concept is supplied with a wall switch.
- New user friendly packaging for an even faster installation.
- High speed motor which is mounted in rubber dampers for low noise operation.

Available dimensions

Minimum width: 180 cm |
Maximum width: | 380 cm

Other options

- Radio frequency: Includes built-in radio frequency receiver, making it possible to operate the screen using the supplied remote control.

Accessories

- All-in-One Control Box
- More on page 62



Leaf shaped case design



Now available with Parallax Ambient Light Rejecting option

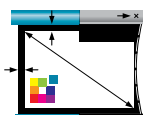
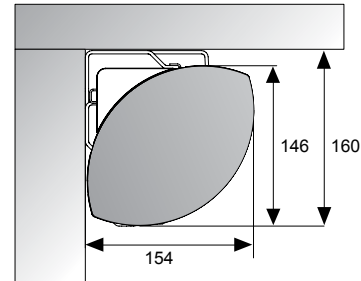

Customise this projection screen to perfectly fit your installation

SUITABLE FOR **ULTRA SHORT THROW** PROJECTION

Dimensions and product codes on



- Matte White**
Viewing Angle: 120°
Gain: 1.0
- High Contrast**
Viewing Angle: 100°
Gain: 1.1
- Datalux**
Viewing Angle: 70°
Gain: 1.5

Elpro Concept

- Stylishly designed electric projection screen for wall or ceiling mounting. If you cannot hide the case into the ceiling, use a projection screen that is worth noticing.
- A five year limited warranty on the Concept range to match the high quality of the products.
- Easy to mount onto a wall or ceiling thanks to the Easy Install system.
- Thanks to Easy Install plug and play connecting the screen to power or one of the many accessories is quick and easy.
- The case and the projection screen surface can be made to exactly the right size and the case is available in any colour for optimal integration into any interior.
- Limit switches are factory set guaranteeing a long life span. The Elpro Concept is supplied with a wall switch.
- New user friendly packaging for an even faster installation.
- High speed motor which is mounted in rubber dampers for low noise operation.

Available dimensions

Minimum width: 180 cm |
Maximum width: | 400 cm

Other options

- Radio frequency: Includes built-in radio frequency receiver, making it possible to operate the screen using the supplied remote control.
- Extended black drop
- Without borders

Accessories

- All-in-One Control Box
- More on page 62



Leaf shaped case design



Easy connectivity

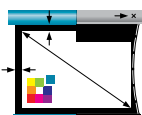
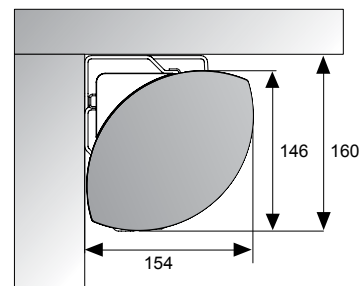

Customise this projection screen to perfectly fit your installation

NOT SUITABLE FOR
ULTRA SHORT THROW
PROJECTION

Dimensions and product codes on

88



- Matte White**
Viewing Angle: 120°
Gain: 1.0
- High Contrast**
Viewing Angle: 100°
Gain: 1.1
- Datalux**
Viewing Angle: 70°
Gain: 1.5

Compact **Electrol**

- High quality electrical projection screen, available in all common aspect ratios.
- Easy to mount onto a wall or ceiling thanks to the Easy Install system.
- The possibilities offered by Easy Install Plug and Play make connecting the screen fast and easy. The many Easy Install accessories are just as convenient and as fast to use.
- The case and the projection screen surface can be made to exactly the right size and the case and slat bar are available in any colour for optimal integration into any interior.
- Limit switches are factory set guaranteeing a long life span. The Compact Electrol is supplied with a wall switch.

Available dimensions

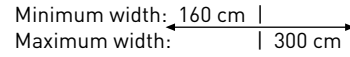

Other options

- Radio frequency: Includes built-in radio frequency receiver, making it possible to operate the screen using the supplied remote control.
- Extended black drop
- Without borders

Accessories

- All-in-One Control Box
- More on page 62



Easy Install with plastic mounting brackets



Plug and Play accessories

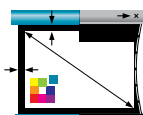
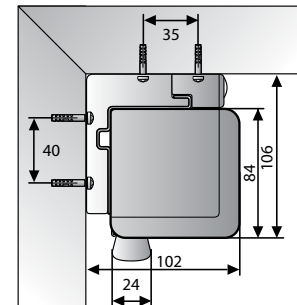

Customise this projection screen to perfectly fit your installation

NOT SUITABLE FOR **ULTRA SHORT THROW** PROJECTION

Dimensions and product codes on

90



Larger Installation

Projection Screens



Product: Elpro Large Electrol Installer: Lagotronics BV Location: Scelta Institute (Venlo, The Netherlands)



39

Extensa

Tensioned
Descender Large Electrol



40



41

Descender Large Electrol

Tensioned
Elpro Large Electrol



42



43

Elpro Large Electrol

Master Electrol



44



E)XTENSA





Large size screen in high resolution
with a perfectly flat surface



HD PROGRESSIVE



16:10 16:9

-  **HD Progressive 0.6**
Viewing Angle: 170°
Gain: 0.6
-  **HD Progressive 0.9**
Viewing Angle: 170°
Gain: 0.9
-  **HD Progressive 1.1**
Viewing Angle: 170°
Gain: 1.1
-  **HD Progressive 1.3**
Viewing Angle: 150°
Gain: 1.3
-  **Dual Vision**
Viewing Angle: 130°
Gain: 0.9

Extensa

- Projection screen for medium to large venue applications with a tab-tensioned projection surface for a perfectly flat viewing area. Available in widths from 4 to 6 metres.
- The Extensa is available with HD Progressive surfaces, the latest technology in projection surfaces designed for 4K and Ultra HD to maximize the technology of your projector.
- Robust case with a powerful motor.
- The projection screen is mounted to the wall and/or ceiling using three brackets which can be positioned flexibly. The brackets can be positioned up to one meter from each side.
- The motor is equipped with electric locks to prevent inadvertent unrolling and features thermal overload cut-off.
- The case and the projection screen surface can be made to exactly the right size and the case is available in any colour for optimal integration into any interior.
- The underside of the case is open as standard. A closed version can be supplied at additional cost.

Available dimensions

Minimum width: 400 cm |
Maximum width: | 600 cm

Accessories

- All-in-One Control Box
- More on page 62



Black anodized aluminium case



Robust case





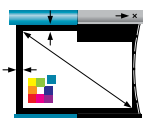



Slat bar retracts into the case



Customise this projection screen to perfectly fit your installation



16:10 16:9 4:3

	HD Progressive 0.6 Viewing Angle: 170° Gain: 0.6		Matte White Viewing Angle: 120° Gain: 1.0
	HD Progressive 0.9 Viewing Angle: 170° Gain: 0.9		Dual Vision Viewing Angle: 130° Gain: 0.9
	HD Progressive 1.1 Viewing Angle: 170° Gain: 1.1		
	HD Progressive 1.3 Viewing Angle: 150° Gain: 1.3		

Tensioned **Descender Large Electrol**

- Ceiling recessed projection screen for medium to large venue applications with a tab-tensioned projection surface for a perfectly flat viewing area. Available in widths from 3.5 to 4.5 metres.
- Easy Serviceability System: once installed, the motor and screen surface remain accessible making adjustments and carrying out maintenance possible.
- Easy to build into existing non-modular ceilings.
- The case and the projection screen surface can be made to exactly the right size and the case is available in any colour for optimal integration into any interior.
- The motor is equipped with electric locks to prevent inadvertent unrolling and features thermal overload cut-off.
- The projection surface is extremely flat, making it suitable for all types of data and video projection.

Available dimensions

Minimum width: 350 cm |
Maximum width: | 450 cm

Accessories

- All-in-One Control Box
- More on page 62

2-step installation

- Order the Screen Case separate from the screen surface. Install the screen case during the rough-in stages and the Screen Surface Assembly at a later stage preventing any damage.
- The Screen Surface Assembly includes the bottom panel of the screen, motor and screen surface.
- Order the case first and decide the aspect ratio and screen surface at a later stage ensuring optimal flexibility.



Easy Serviceability System



Perfect integration into the ceiling

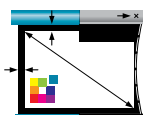
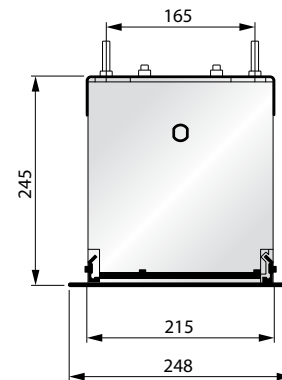

Customise this projection screen to perfectly fit your installation



Matte White
Viewing Angle: 120°
Gain: 1.0

Descender Large Electrol

- Ceiling recessed projection screen for medium to large venue applications. Available in widths from 3.5 to 5 metres.
- Closure formed by the slat bar ensures that ceiling mounting is inconspicuous.
- Easy Serviceability System: once installed, the motor and screen surface remain accessible making adjustments and carrying out maintenance possible.
- Easy to build into existing non-modular ceilings.
- The case and the projection screen surface can be made to exactly the right size and the case and slat bar are available in any colour for optimal integration into any interior.
- The motor is equipped with electric locks to prevent inadvertent unrolling and features thermal overload cut-off.

Available dimensions

Minimum width: 350 cm |
Maximum width: | 500 cm

Other options

- Without border

Accessories

- All-in-One Control Box
- More on page 62

2-step installation

- Order the Screen Case separate from the screen surface. Install the screen case during the rough-in stages and the Screen Surface Assembly at a later stage preventing any damage.
- The Screen Surface Assembly includes the bottom panel of the screen, motor and screen surface.
- Order the case first and decide the aspect ratio and screen surface at a later stage ensuring optimal flexibility.



Easy Serviceability System



Perfect integration into the ceiling

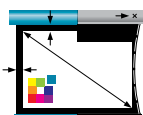
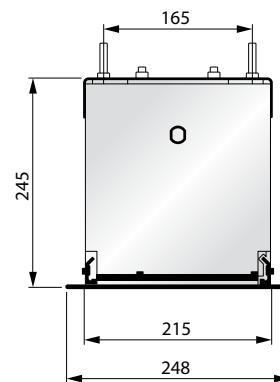







Customise this projection screen to perfectly fit your installation



HD PROGRESSIVE



16:10 16:9 4:3

	HD Progressive 0.6 Viewing Angle: 170° Gain: 0.6		Matte White Viewing Angle: 120° Gain: 1.0
	HD Progressive 0.9 Viewing Angle: 170° Gain: 0.9		Dual Vision Viewing Angle: 130° Gain: 0.9
	HD Progressive 1.1 Viewing Angle: 170° Gain: 1.1		
	HD Progressive 1.3 Viewing Angle: 150° Gain: 1.3		

Tensioned **Elpro Large Electrol**

- Projection screen for medium to large venue applications with a tab-tensioned projection surface for a perfectly flat viewing area. Available in widths from 4 to 4.5 metres.
- Flexible mounting brackets are standard with one metre of lateral adjustment from each end cap for easy positioning.
- For optimal connectivity, the Tensioned Elpro Large Electrol can also be operated using the Easy Install accessories.
- Easy Serviceability System: once installed, the motor remains accessible making adjustments and carrying out maintenance possible.
- Robust steel case with high speed, low noise motor.
- The motor is equipped with electric locks to prevent inadvertent unrolling and features thermal overload cut-off.
- The case and the projection screen surface can be made to exactly the right size and the case is available in any colour for optimal integration into any interior.

Available dimensions

Minimum width: 400 cm |
Maximum width: | 450 cm

Accessories

- All-in-One Control Box
- More on page 62



Easy Install



Easy Serviceability

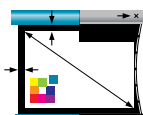
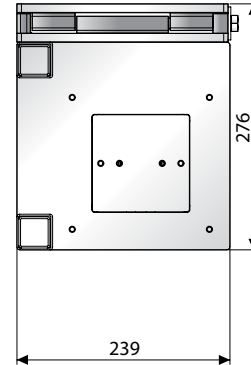

Customise this projection screen to perfectly fit your installation



Matte White
Viewing Angle: 120°
Gain: 1.0

Elpro Large Electrol

- Projection screen for medium to large venue applications. Available in widths from 4 to 5 metres with a maximum height of 6 metres.
- Flexible mounting brackets are standard with one metre lateral adjustment of each end cap for easy positioning.
- For optimal connectivity, the Elpro Large Electrol can also be operated using the Easy Install accessories
- Easy Serviceability System: once installed, the motor remains accessible making adjustments and carrying out maintenance possible.
- Robust steel case with high speed, low noise motor.
- The motor is equipped with electric locks to prevent inadvertent unrolling and features thermal overload cut-off.
- The case and the projection screen surface can be made to exactly the right size and the case and slat bar are available in any colour for optimal integration into any interior.

Available dimensions

Minimum width: 400 cm |
Maximum width: | 500 cm

Other options

- Without border

Accessories

- All-in-One Control Box
- More on page 62



Easy Install



Easy Serviceability

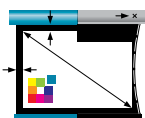
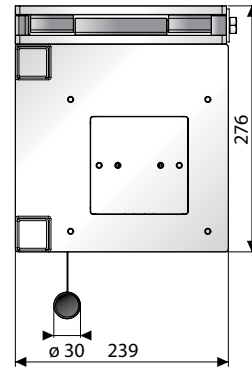

Customise this projection screen to perfectly fit your installation



16:10 4:3 1:1

Matte White
Viewing Angle: 100°
Gain: 1.0

Retrotex
Viewing Angle: 60°
Gain: 0.5

Master Electrol

- Projection screen for medium to large venue applications. Available in widths from 4 to 5 metres with a maximum height of 4 metres.
- A projection screen with a designer look provided by its round aluminium case.
- Limit switches are factory set guaranteeing a long life span. The Master Electrol is supplied with a wall switch.
- The projection screen is mounted to the wall and/or ceiling using supplied brackets which can be positioned laterally.
- Also available with a rear projection screen surface in addition to Matte White. The seam in the rear projection screen surface may be slightly visible under projection.
- The case and the projection screen surface can be made to exactly the right size.

Available dimensions

Minimum width: 400 cm |
Maximum width: | 500 cm

Accessories

- All-in-One Control Box
- More on page 62

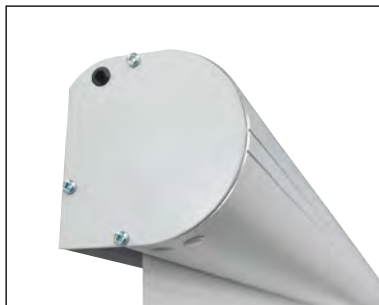

Designer round aluminium case



Laterally adjustable mounting brackets

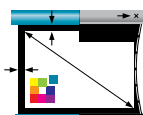
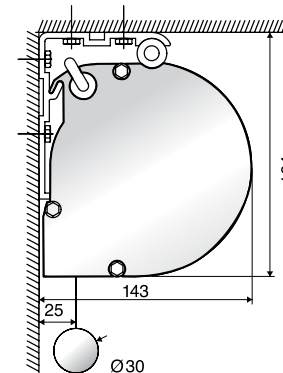

Customise this projection screen to perfectly fit your installation

Matte White projection surface in this projection screen is a vinyl based material without black backing.

Dimensions and product codes on



PROJECTA impressions

Fixed Frame Projection Screens

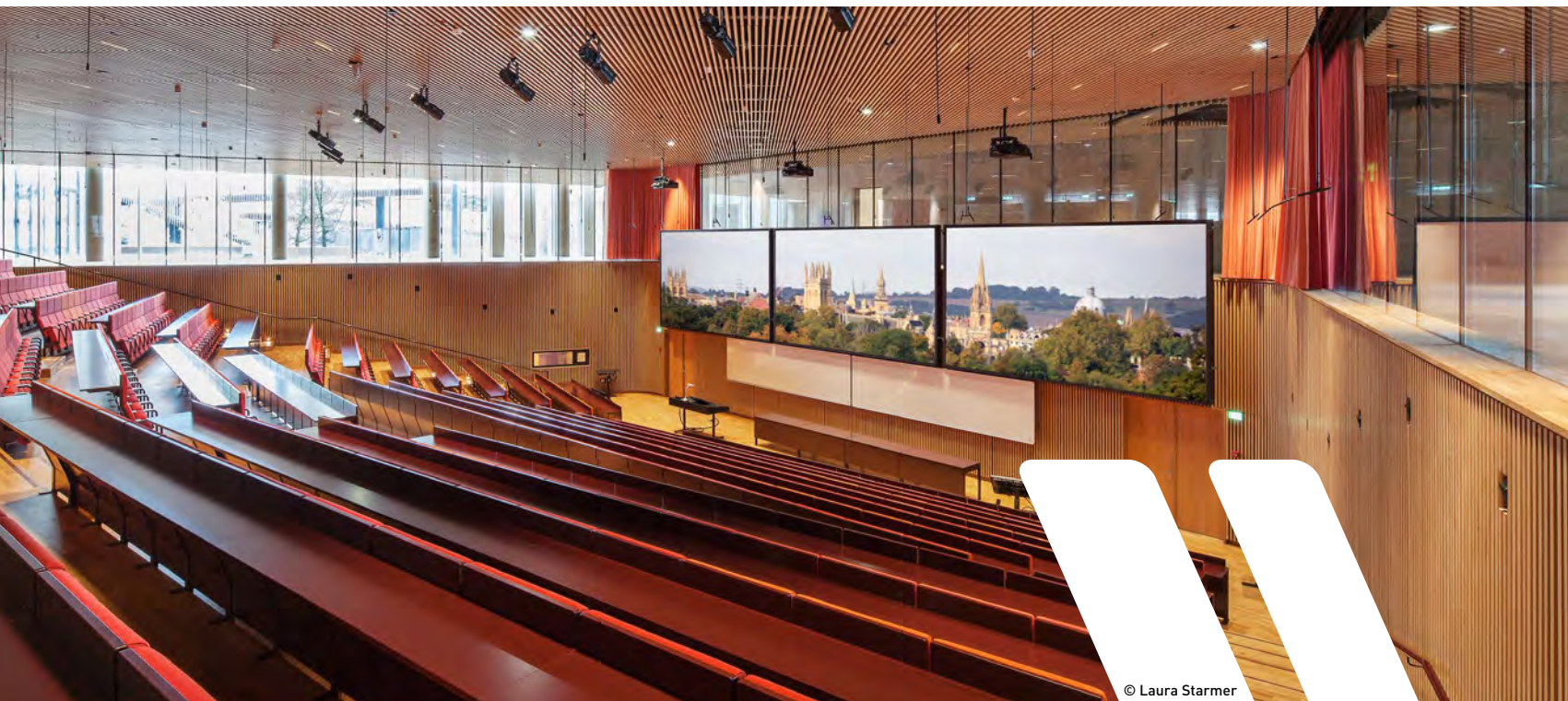

© Laura Starmer

Product: FullVision Installer: Stouenborg / Imago Sonas Location: Mærsk Building (Copenhagen, Denmark)

49



Parallax 0.8

49



Parallax UST 0.45

50



**HomeScreen
Deluxe**

51



HomeScreen

52



FullVision

53



EyeletPro



ambient light rejection technology

standard technology

**blocks
ambient light** for a bright
and large image

PARALLAX

Parallax is a projection technology that features an advanced optical lens system that rejects light, rather than only diffusing light. Parallax is made up of multiple micro-layers to achieve its light blocking properties and superior viewing angles. Each micro-layer has a function in creating the brightly lit display. Layers that are black boost contrast and absorb ambient light from the sides, while a specially shaped layer blocks light from above. Two ambient light rejecting surfaces are available in a fixed frame; Parallax 0.8 for standard throw projectors and Parallax UST 0.45 for ultra short-throw projectors. Both products are flexible, shipping in a roll, and feature speckle and glare-free surfaces.

Now also available in motorized projection screens!

- Tensioned DescenderPro - page 26
- Tensioned Elpro Concept - page 32

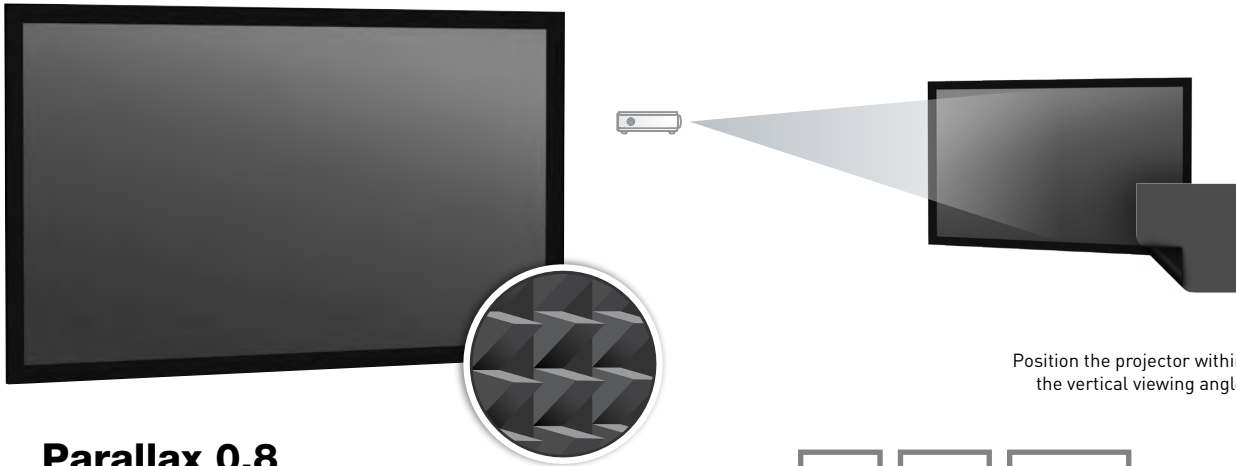

Position the projector within the vertical viewing angle

Parallax 0.8

Parallax is an ambient light-rejecting technology that features a micro-layered optical lens system that rejects light. With extremely wide viewing angles, no speckle and no glare, the surface is ideal for applications in Pro AV. Additionally, the surface is flexible, ships in a roll and is easy to install.

Each layer of Parallax plays a role in preserving the image that is reflected back to the viewer in high ambient light environments. Some layers absorb light while one special layer is shaped like a microscopic saw-tooth that blocks light from above resulting in the preservation of high-contrast, bright images in brightly lit environments.

The projector needs to be positioned within the vertical viewing angle to ensure the light is not rejected.

- 16:10
- 16:9
- 2.35:1

Available dimensions

Minimum width: 170 cm |
 Maximum width: | 347 cm

Gain: 0.8
 Horizontal Viewing Angle: 170°
 Vertical Viewing Angle: 34°

**NOT SUITABLE FOR
 ULTRA SHORT THROW
 PROJECTION**

Dimensions and product codes on

94

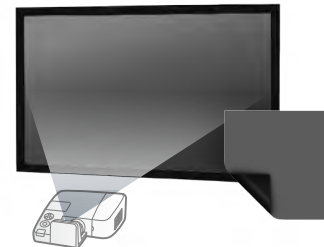

Position the projector underneath the screen

Parallax UST 0.45

Parallax is an ambient light-rejecting technology that features a micro-layered optical lens system that rejects light. Parallax UST 0.45 is unique because it is designed to be used with an ultra short-throw projector that is placed below the screen.

With extremely wide viewing angles, no speckle and no glare, the surface is ideal for applications in Pro AV. Additionally, the surface is flexible, ships in a roll and is easy to install.

Each layer of Parallax plays a role in preserving the image that is reflected back to the viewer in high ambient light environments. Some layers absorb light while one special layer is shaped like a microscopic saw-tooth that blocks light from above resulting in the preservation of high-contrast, bright images in brightly lit environments.

- 16:10
- 16:9

Available dimensions

Minimum width: 170 cm |
 Maximum width: | 265 cm

Gain: 0.45
 Horizontal Viewing Angle: 160°
 Vertical Viewing Angle: 110°

**SUITABLE FOR
 ULTRA SHORT THROW
 PROJECTION**

Dimensions and product codes on

94



HD PROGRESSIVE

HomeScreen Deluxe

- Luxurious, high quality fixed frame screen with a black velvet frame finish and a wide selection of screen surfaces.
- The flat aluminium frame for the HomeScreen Deluxe has a black velvet cover, which eliminates reflection and serves to absorb projected light.
- The frame (8 cm wide and 3 cm deep) features a beveled edge, reducing shadowing in the viewing area.
- The projection screen surface is attached to the rear of the screen with Velcro®.
- The frame and projection screen surface can be custom made to project requirements.
- The projection surface is exceptionally flat, making it suitable for all types of data and video projection.
- The frame is easy to mount with the supplied mounting brackets.



16:10	16:9	2.35:1	4:3
-------	------	--------	-----

	HD Progressive 0.6 Viewing Angle: 170° Gain: 0.6		HD Progressive 1.1 Contrast Viewing Angle: 120° Gain: 1.1
	HD Progressive 0.9 Viewing Angle: 170° Gain: 0.9		HD Progressive 1.1 Perf Viewing Angle: 170° Gain: 1.1
	HD Progressive 1.1 Viewing Angle: 170° Gain: 1.1		Matte White Viewing Angle: 120° Gain: 1.0
	HD Progressive 1.3 Viewing Angle: 150° Gain: 1.3		Dual Vision Viewing Angle: 130° Gain: 0.9

Available dimensions

Minimum width: 176 cm |
Maximum width: | 516 cm

Accessories

- BrightSight for safely cleaning the projection surface



Black velvet frame finish



Projection surface attaches with Velcro®

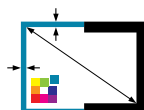

Customise this projection screen to perfectly fit your installation

SUITABLE FOR **ULTRA SHORT THROW** PROJECTION

Dimensions and product codes on



16:10

16:9

2.35:1

4:3



Matte White
Viewing Angle: 120°
Gain: 1.0



Dual Vision
Viewing Angle: 130°
Gain: 0.9

HomeScreen

- High quality fixed frame screen with a matte black frame and a wide selection of screen surfaces.
- The aluminium frame for the HomeScreen has a black matte finish.
- The frame (8 cm wide and 3 cm deep) features a beveled edge, reducing shadowing of the image.
- The projection screen surface is attached to the rear of the screen with Velcro®.
- The frame and projection screen surface can be custom made to project requirements.
- The projection surface is exceptionally flat, making it suitable for all types of data and video projection.
- The frame is easy to mount with the supplied mounting brackets.

Available dimensions

Minimum width: 176 cm |
Maximum width: | 316 cm

Accessories

- BrightSight for safely cleaning the projection surface



Black matte frame finish



Projection surface attaches with Velcro®

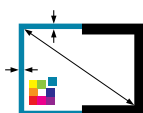

Customise this projection screen to perfectly fit your installation

SUITABLE FOR
ULTRA SHORT THROW
PROJECTION









Dimensions and product codes on

95



16:10 16:9

<p> HD Progressive 0.6 Viewing Angle: 170° Gain: 0.6</p> <p> HD Progressive 0.9 Viewing Angle: 170° Gain: 0.9</p> <p> HD Progressive 1.1 Viewing Angle: 170° Gain: 1.1</p>	<p> HD Progressive 1.3 Viewing Angle: 150° Gain: 1.3</p> <p> HD Progressive 1.1 Contrast Viewing Angle: 120° Gain: 1.1</p> <p> Matte White Viewing Angle: 120° Gain: 1.0</p>
--	--

FullVision

- Completely border-less and low-profile fixed frame projection screen that enables the entire surface to be used for projection.
- The FullVision is available with HD Progressive surfaces, the latest technology in projection surfaces designed for 4K and Ultra HD to maximize the technology of your projector.
- The projection surface is wrapped around the aluminum frame (8 cm wide and 3 cm deep) and is attached to the rear of the screen with Velcro®.
- The FullVision is a low-profile lightweight frame screen that is mounted close to the wall for an inconspicuous installation with supplied mounting brackets.
- The FullVision is easy to assemble and includes an innovative corner design for a fast installation.
- The FullVision is available in custom sizes up to 400 cm height and 600 cm width.
- All projection surfaces are seamless within the viewing area and exceptionally flat, making it suitable for all types of data and video projection.
- Ceiling and free-standing installations are optionally available on request. Please contact us with your requirements.

Available dimensions

Minimum width: 200 cm |
Maximum width: | 600 cm

Accessories

- BrightSight for safely cleaning the projection surface
- More on page 67



The surface is wrapped around the frame



Low profile installation



Projection surface attaches with Velcro®

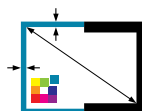

Customise this projection screen to perfectly fit your installation

SUITABLE FOR
ULTRA SHORT THROW
PROJECTION 









Dimensions and product codes on

95



HD PROGRESSIVE



	HD Progressive 0.6 Viewing Angle: 170° Gain: 0.6		HD Progressive 0.9 Viewing Angle: 170° Gain: 0.9
	HD Progressive 1.1 Viewing Angle: 170° Gain: 1.1		Ultra Wide Angle Viewing Angle: 130° Gain: 0.9
	Dual Vision Viewing Angle: 130° Gain: 0.9		HD Progressive 1.3 Viewing Angle: 150° Gain: 1.3
	Matte White Viewing Angle: 120° Gain: 1.0		HD Progressive 1.1 Contrast Viewing Angle: 120° Gain: 1.1
	HD Progressive 1.1 Contrast Perf* Viewing Angle: 120° Gain: 1.1 (*max. height 250 cm)		

EyeletPro

- Custom Lace and grommet tensioned screen surfaces for a permanent fixed or fly screen with a user-supplied frame up to a width of 11 meters.
- The EyeletPro is available with HD Progressive surfaces, the latest technology in projection surfaces designed for 4K and Ultra HD to maximize the technology of your projector.
- The borders of the projection material can be finished to match your installation-needs. Choose for an edge with non-reflective eyelets with spacing up to 20 cm.
- Built exactly according to requested size. The custom EyeletPro surfaces can be ordered up to a width of 11 meters wide and 4.88 meters in height.
- All projection surfaces are seamless within the viewing area and have black backing.
- High resolution projection surfaces can now be installed in locations with large pre-existing frames or used in truss-based event installations.

Available dimensions

Maximum height: 478 cm |
Maximum width: | 488 cm



**LARGE AUDITORIUMS OR
THEATERS WITH EXISTING
FRAMES**



**LIVE EVENTS WITH
TRUSS-BASED
INSTALLATIONS**



**MUSEUMS AND
EXPOSITIONS**



**CREATIVE ART
INSTALLATIONS
WITH LIGHT**

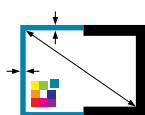

Customise this
projection screen
to perfectly fit
your installation

SUITABLE FOR
ULTRA SHORT THROW
PROJECTION 

Dry Erase Projection Screens



57



Dry Erase Screen

57



Dry Erase Screen
Panoramic

Dry Erase Projection Screens

The latest Dry Erase Screen features upgraded durability, surface uniformity and rigidity to ensure a superior interactive experience. The erasable surface is hotspot-free under projection, and now comes with new standard features - all Dry Erase Screens are magnetic and have a thin frame. It can be used with an ultra short throw projector as an interactive screen or as a whiteboard with dry erase markers.



Marker board capabilities



Designed for interactive and ultra short throw projectors

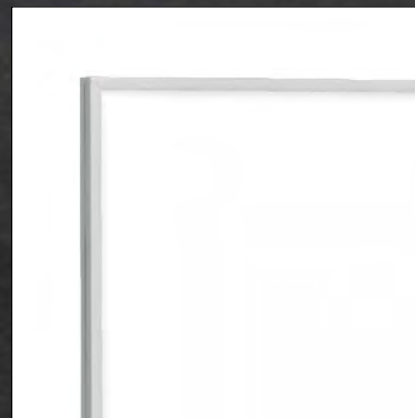

A sleek extruded aluminium frame finish

- The Projecta Dry Erase Screen is a revolutionary dual-purpose projection screen and writable marker board combination. A unique projection screens that provides the functionality of a dry erase board without sacrificing the ability to display a clear and vibrant image.
- The Dry Erase Screen is designed to be wall mounted and will integrate seamlessly into any classroom, training room or meeting space where both a projection screen and dry erase surface are required.
- The Dry Erase Screen is designed to be used with interactive short throw projectors.
- What makes this screen exceptional is that it has a superior projection surface that can be written on with dry erase markers.
- The projection surface has professional features such as a gain of 2.5 and 50 degree viewing angle, which practically eliminates the ambient light glare and hotspot that are known with standard whiteboards.
- The Dry Erase Screen has a sleek extruded brushed aluminum color frame finish and ships with a convenient tray for storage of markers, erasers and interactive tools.
- The included wall mount features a quick connect easy install method and low profile installation.
- A dry erase marker kit is included, which contains four markers and a cleaning cloth.

Quality projection surface combined with marker board capabilities

Often a marker board is misused as a projection surface which creates a glaring, hard to read projected image with a clear hotspot in the center. The Dry Erase Screen is a professional quality projection screen with a surface that can be written on with dry erase markers. The projection surface offers a gain of 2.5 and a viewing angle of 50 degrees which practically eliminates the ambient light glare and hotspot.

Easy and low profile installation

The Dry Erase Screen is designed to be wall mounted. The included wall mount features a quick connect easy install method and low profile installation. A convenient tray is included at the base of the assembly for storage of dry erase markers, erasers and interactive tools.

Interactivity

The Projecta Dry Erase Screen is designed to be used with [interactive] short throw projectors. The rigid projection surface makes it ideal for the use of interactive tools that can be used with a projector.



Dry Erase Screen

Superior projection quality surface with magnetic dry erase marker board functionality.

16:9 16:10

SUITABLE FOR **ULTRA SHORT THROW PROJECTION**

Available dimensions
 Minimum width: 146 cm |
 Maximum width: | 269 cm

Dimensions and product codes on **96**



Dry Erase Screen Panoramic

Three panel design to cover large walls with magnetic dry erase marker board functionality. The center panel is formatted for projection with side panels for collaborative writing space.

16:9 16:10

SUITABLE FOR **ULTRA SHORT THROW PROJECTION**

Available dimensions
 Minimum width: 366 cm |
 Maximum width: | 488 cm

Dimensions and product codes on **96**

Manual Wall and Ceiling Mounted Screens

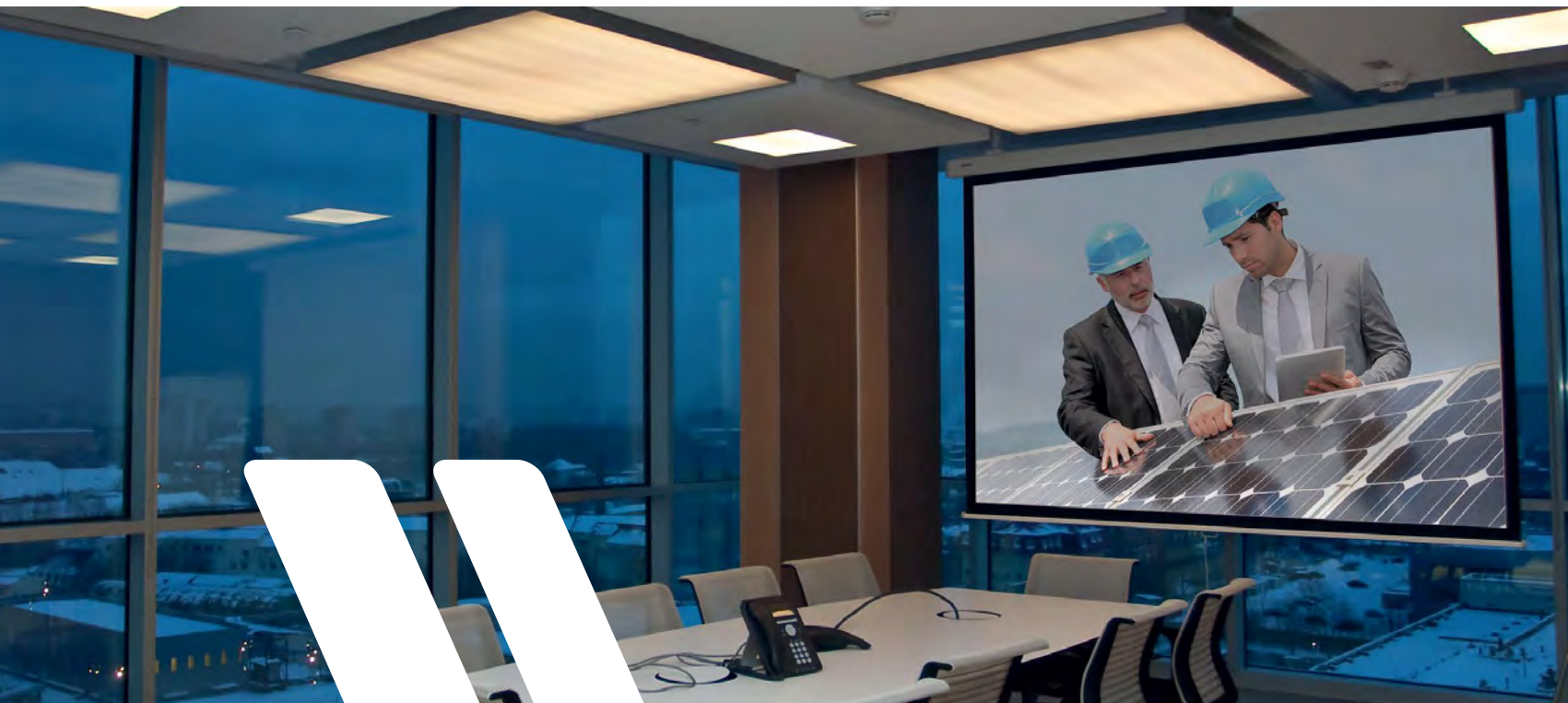

Product: ProScreen Installer: Auvix Location: HP (Moscow, Russia)

Hapro CSR



58

59

ProScreen CSR



SlimScreen



59



- Matte White**
Viewing Angle: 120°
Gain: 1.0
- High Contrast**
Viewing Angle: 100°
Gain: 1.1
- Datalux**
Viewing Angle: 70°
Gain: 1.5

Hapro CSR

- Professional quality manual projection screen with the reliable Controlled Screen Return, available in various aspect ratios and screen surfaces.
- The special Controlled Screen Return spring mechanism for the Hapro CSR is very strong. It retracts the projection surface quickly for the first part and then slows down to roll into the case smoothly.
- The Hapro CSR needs to be fully extracted. There are no intermediate stopping positions.
- Easy to mount onto a wall or ceiling thanks to the Easy Install system.
- The case and the projection screen surface can be made to exactly the right size and the case and slat bar are available in any colour for optimal integration into any interior.
- The triangular slat bar retracts into the case for a clean finish.

Available dimensions

Minimum width: 200 cm |
Maximum width: | 340 cm

Other options

- Without border

Accessories

- Pull Rod
- BrightSight for safely cleaning the projection surface
- More on page 64



Smooth retraction with CSR



Easy Install with metal brackets

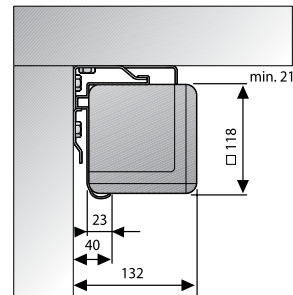

NOT SUITABLE FOR
ULTRA SHORT THROW
PROJECTION

Dimensions and product codes on



Smooth retraction with CSR



Easy Install with plastic brackets



- Matte White**
Viewing Angle: 120°
Gain: 1.0
- High Contrast**
Viewing Angle: 100°
Gain: 1.1
- Datalux**
Viewing Angle: 70°
Gain: 1.5

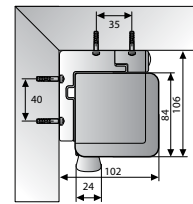

ProScreen CSR

- High quality manual projection screen with the reliable Controlled Screen Return, available with various aspect ratios and screen surfaces.
- The Projecta Controlled Screen Return (CSR) allows for the projection screen surface to retract gently into the case in a smooth and controlled manner.
- The ProScreen CSR is available with the CSR spring mechanism up to a width of 240 cm.
- The screen locks into place at 13 cm intervals for possible height adjustment.
- Easy to mount on a wall or ceiling thanks to the Easy Install system.
- The case and the projection screen surface can be made to exactly the right size and the case and slat bar are available in any colour for optimal integration into any interior.

Available dimensions

Minimum width: 180 cm |
Maximum width: 280 cm

Other options

- Extended black drop
- Without border
- Standard (non-CSR) spring

NOT SUITABLE FOR
ULTRA SHORT THROW
PROJECTION

Accessories

- Pull Rod
- BrightSight for safely cleaning the projection surface
- More on page 64

Dimensions and product codes on

97



Triangular slat bar



Integrated mounting brackets



- Matte White**
Viewing Angle: 120°
Gain: 1.0
- Datalux**
Viewing Angle: 70°
Gain: 1.5

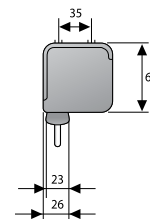

SlimScreen

- Basic manual projection screen with spring mechanism.
- Supplied in the most compact case.
- Easy to mount to a wall or ceiling using the integrated mounting brackets on each end cap.
- The screen locks into place at 11 cm intervals for possible height adjustment.
- The intervals are at 15 cm for screen widths of 200 cm.

Available dimensions

Minimum width: 160 cm |
Maximum width: 240 cm

Other options

- Without border

NOT SUITABLE FOR
ULTRA SHORT THROW
PROJECTION

Accessories

- Pull Rod
- BrightSight for safely cleaning the projection surface
- More on page 64

Dimensions and product codes on

99



Simple, foot-operated
toe-release mechanism



Self locking handle for
height adjustment

16:10

16:9

4:3

1:1



Matte White
Viewing Angle: 120°
Gain: 1.0



Datalux
Viewing Angle: 70°
Gain: 1.5

Picture King®

- Professional quality projection screen on a tripod, well known for its stability and durability under intensive, portable use.
- The Picture King® has a very stable tripod made from square tubing and features a simple, foot-operated toe-release mechanism.
- Special transport lock protects the screen surface from damage.
- Self-locking handle for optimum height adjustment and portability.
- Integrated OHP bracket for keystone correction with a length of 40 cm.
- An optional black Polyknit Skirting Kit is available for the Picture King®.

Screen Bag

Protective cover protects the tripod screen from dust and prevents damage during transportation.



Type	Product Code
Screen width 127 - 152 cm	10830043
Screen width 178 cm	10830045
Screen width 213 cm	10830046
Screen width 244 cm	10830047

Available dimensions

Minimum width: 152 cm |
Maximum width: | 244 cm

Other options

- Carpeted case: The Carpeted Picture King® is covered with black carpet for rental situations. Industrial grade carpet protects the screen case against nicks and scratches that can occur with a portable screen.

Accessories

- Screen Bag
- BrightSight for safely cleaning the projection surface



Pneumatic tensioning arm

16:9

4:3

Matte White High Gain
Viewing Angle: 70°
Gain: 2.2

LiteScreen

- Lightweight, portable projection screen in Video and HDTV format sizes.
- The flexible pneumatic tensioning arm makes it possible for the height to be adjusted infinitely and flexibly.
- Supplied with an extra black lower border as standard for adjusting to the ideal viewing height.
- The LiteScreen has two feet which rotate out when setting up ensuring stability.
- The case is made of aluminium with a black matte finish.

Available dimensions

Minimum width: 122 cm |
Maximum width: 203 cm

Accessories - control options



All-In-One Control Box

Controlling a projection screen has never been this easy! The new Projecta All-in-One Control Box offers multiple operation options in a single box. This new accessory can be combined with motorized projection screens without a built-in RF receiver and offers the following options:

- Relay (dry-contact)
- RF (radiofrequency) control
- IR (infrared) control
- Manual Switch on the box
- 12 volt trigger

Relay (dry-contact)

Use the relay dry contact points in the control box to connect the screen to be operated with a third party control system. A control system includes the projection screen into the full room AV control.

RF (radiofrequency) control

Control the projection screen via a radio frequency remote control. The remote control unit operates on frequency 433.92 MHz. RF has an effective range up to 30 meters, depending on the local environment.

IR (infrared)

Control the projection screen via an infrared remote control. For infrared control a direct line of sight with the control box is needed. IR can be a solution for environments with restricted RF access. Infrared has an effective range up to 8 meters.

Manual Switch

On the side of the control box you can find three buttons to control the projection screen directly. This additional control method function as a back-up to ensure the screen can still be operated even when connected control options fail.

12 volt DC trigger

Connect the 12 volt trigger option to any 12 volt output to trigger the projection screen. The 12 volt can be from a projector 12 volt trigger output or from an AV control system.

10800154 EU



IR (infrared)

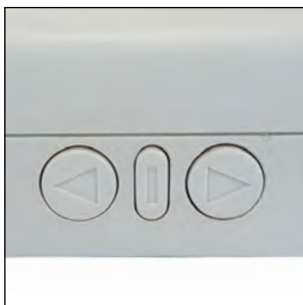

Manual Switch



12 volt DC trigger

Easy ordering

No need to decide upfront on how to control the projection screen any more. You can order this versatile accessory with the projection screen and decide closer to the actual installation on which option to use.

Easy Installation

Not every installation always goes exactly according to plan and on-site the installer might have to get creative to get everything to work. Having an accessory that does not restrict you to only one connection or control option gives the required flexibility. Even when all connected control systems fail, this control box has a manual switch to operate the projection screen to start the presentation.

Available for

- Tensioned DescenderPro
- DescenderPro
- Tensioned Elpro Concept
- Elpro Concept
- Compact Electrol
- Extensa
- Tensioned Descender Large Electrol
- Descender Large Electrol
- Tensioned Elpro Large Electrol
- Elpro Large Electrol
- Master Electrol
- GiantScreen
- Studio Electrol
- Arena Electrol



Power Sensing Trigger

The Power Sensing Trigger will turn every installation into an easy control system. Usually a projector needs to have a 12 volt trigger output to send the projection screen a signal to unroll when the system is turned on. Not every projector however has this trigger output, but the Projecta Power Sensing trigger will now give every projection system that functionality.

The Power Sensing trigger will be connected in between the power source and the projector. When the projector is turned on, the trigger senses power going to the projector and signal the projection screen to unroll. When the power is switched of the trigger will signal the projection screen to retract again.

10800155 EU

How it works:

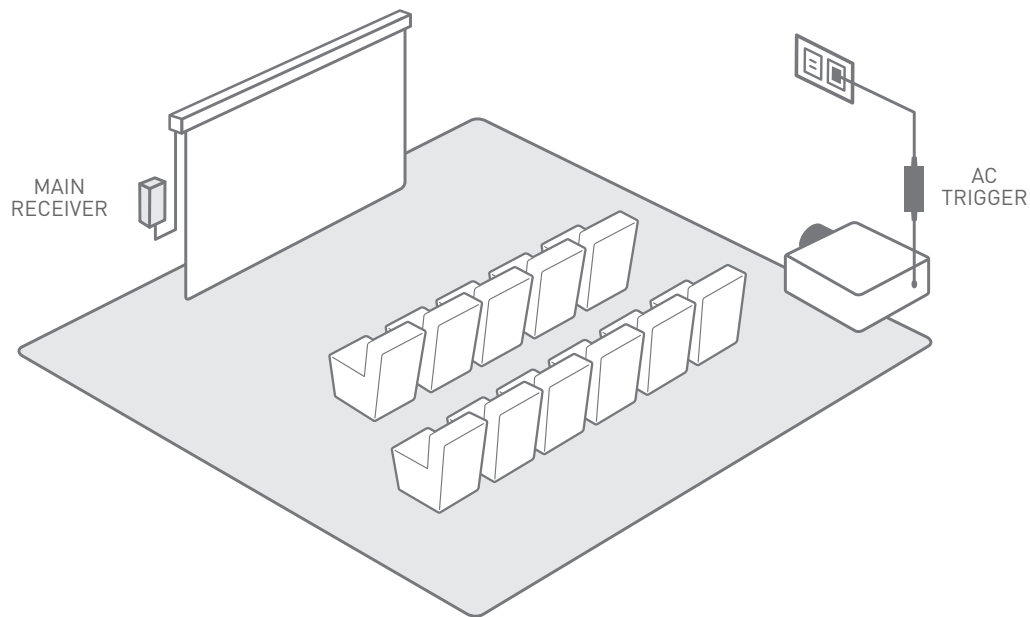

Available for

- Tensioned DescenderPro
- DescenderPro
- Tensioned Elpro Concept
- Elpro Concept
- Compact Electrol
- Extensa
- Tensioned Descender Large Electrol
- Descender Large Electrol
- Tensioned Elpro Large Electrol
- Elpro Large Electrol
- Master Electrol
- GiantScreen
- Studio Electrol
- Arena Electrol

Accessories - control options



**Easy Install
Plug and Play
RF Remote Control**

Simply add a RF Remote Control to a projection screen by connecting the receiver box with the Easy Install connector. The remote control unit operates on frequency 868.3 MHz and is supplied with a five-channel hand-held transmitter, a Plug and Play receiver unit and a five-metre long, black cable. The five-channel hand held transmitter enables the operation of five projection screens using one remote control. Available with European, UK or Swiss plug.
10800055 EU
10800066 UK
10800067 CH



**Easy Install
Plug and Play
IR Remote Control**

Simply add an Infrared Remote Control to a projection screen by connecting the receiver box with the Easy Install connector. The remote control unit operates on infrared signal and is supplied with a one-channel hand-held transmitter, a plug and play receiver with an integrated infrared eye and a five-metre long, black cable. Potential-free contacts are available in the IR remote control case. This allows a screen to be connected to a control system or wall switch. Available with European, UK or Swiss plug.
10800058 EU
10800072 UK
10800073 CH



**Easy Install
RF Wall-Mounted Transmitter**

For projection screens that are controlled with the RF Remote Control accessory a separate RF wall switch is available. This wall-mounted transmitter can be added to this configuration and operates on frequency 868.3 MHz. This accessory can only be used in combination with the Easy Install Plug and Play RF Remote Control. The wall mounted transmitter is ready for immediate use as a battery is included.
10800065



**Easy Install
Plug and Play Relay Box with
Potential-Free Contacts**

The Relay Box is essential to integrate a projection screen into a control system. By connecting the Easy Install connector the Relay Box and the projection screen can communicate. In the Relay Box potential-free contacts are available to easily connect the screen to a control system. The Relay Box is connected with constant voltage and is available with European, UK or Swiss plug.
10800068 EU
10800084 UK
10800083 CH



**Easy Install
Plug and Play
RS232 with IP Control Kit**

With the RS232 with IP Control Kit a projection screen can be operated with RS232 serial protocol over Internet (IP). This accessory can only be used in combination with the Easy Install Relay Box with Potential-Free Contacts. Now the projection screen can be operated from any location.
10800085



Key Switch

A key switch is the solution for preventing unwanted use of an electric projection screen. The key serves as the switch and limits the use of the projection screen to selected personnel.
10800009

manual operation

Available for

- Hapro CSR
- ProScreen CSR
- ProScreen
- SlimScreen



Pull Rod

If a projection screen with a spring mechanism is mounted at a height of more than 2.5 metres, then a pull rod is a useful accessory for unrolling the screen. The pull rod has a length of 125 cm.
10800021

Available for

- Tensioned DescenderPro
- DescenderPro
- Tensioned Elpro Concept
- Elpro Concept
- Compact Electrol
- Extensa
- Tensioned Descender Large Electrol
- Descender Large Electrol
- Tensioned Elpro Large Electrol
- Elpro Large Electrol
- Master Electrol



**Easy Install
Wireless Projector Coupling**

For projection screens that are controlled with the RF Remote Control accessory a trigger accessory is available that unrolls the projection screen when the projector is activated. The Projector Coupling can be connected to projectors with a 12 Volt DC/85 mA output and operates on frequency 868.3 MHz. This accessory can only be used in combination with the Easy Install Plug and Play RF Remote Control. The transmitter is battery powered and is programmed via the RF receiver.
10800056



**Easy Install
RF Remote Control with
Wireless Projector Coupling**

This accessory is a combination of the Easy Install RF Remote Control and the Wireless Projector Coupling accessories. This complete set will unroll the projection screen when the projector is activated. The Projector Coupling can be connected to projectors with a 12 Volt DC/85 mA output and operates on frequency 868.3 MHz.
10800057 EU
10800070 UK
10800069 CH



**Easy Install
Projector Coupling with Cable**

The wired Projector Coupling can be connected to projectors with a 12 Volt DC/85 mA output and is directly connected to the projection screen. This accessory functions as a trigger that unrolls the projection screen when the projector is activated. The Projector Coupling with cable is equipped with a manual override switch on the trigger case and is supplied with a five-metre long, black cable. Available with European, UK or Swiss plug.
10800059 EU
10800074 UK
10800075 CH



**Easy Install
Plug and Play
RS232 Control Kit**

With the RS232 Control Kit a projection screen can be operated with RS232 serial protocol. This accessory can only be used in combination with the Easy Install Relay Box with Potential-Free Contacts. A distance of 44 metres can be covered by using a UTP CAT 5 cable.
10800080

RF Motor control options



RF Wall-Mounted Transmitter

For projection screens that have a built-in RF receiver a separate RF wall switch is available. This wall-mounted transmitter can be added to this configuration and operates on frequency 433.92 MHz. The wall mounted transmitter is ready for immediate use as a battery is included.
10800108



4-channel RF Remote Control

This remote control can be added or replace the standard one-channel RF Remote Control that is supplied with projection screens with a built-in RF receiver. This 4-channel remote control allows operation of up to four projection screens with integrated RF (433.92 MHz) controls at the same time. The screens can be operated individually or on a group basis.
10800107

Available for

- Tensioned DescenderPro RF
- DescenderPro RF
- Tensioned Elpro Concept RF
- Elpro Concept RF
- Compact RF Electrol

Accessories - installation

Wall Bracket

In certain cases it is advisable to mount the projection screen away from the wall. For example, this may be because there is a painting on the wall at the point where the projection screen should be mounted. In the case of overhead projection, it can also be necessary to position the projection screen fabric at an angle in order to prevent distortion of the image.



75 cm



40 cm



10 cm

Bracket	White RAL 9016	Black RAL 7021	Aluminium	Available for
	Product Code	Product Code	Product Code	
Wall Bracket 75 cm	10800001	10800020		Tensioned DescenderPro, DescenderPro, Tensioned Elpro Concept, Elpro Concept, Compact Electrol, Hapro CSR, ProScreen CSR, ProScreen
Wall Bracket 30 cm	10800041	10800042		Tensioned Elpro Concept, Elpro Concept, Compact Electrol, Hapro CSR, ProScreen CSR, ProScreen
Wall Bracket 10 cm	10800090	10800091		Tensioned Elpro Concept, Elpro Concept, Compact Electrol, Hapro CSR, ProScreen CSR, ProScreen
Wall Bracket Elpro Large Electrol 40 cm	10800008			Tensioned Elpro Large Electrol, Elpro Large Electrol
Wall Bracket Master Electrol 40 cm			10800077	Master Electrol
Wall Bracket SlimScreen 57 cm	10800036	10800040		SlimScreen



Ceiling Bracket

Special ceiling brackets are available for mounting a projection screen in a room with a high ceiling or under a recessed ceiling. The ceiling brackets can be shortened on site as required.

Bracket	White RAL 9016	Black RAL 7021	Aluminium	Available for
	Product Code	Product Code	Product Code	
Ceiling Bracket M8 100 cm	10800004	10800017		Tensioned DescenderPro, DescenderPro, Tensioned Descender Large Electrol, Descender Large Electrol, Tensioned Elpro Concept, Elpro Concept, Hapro CSR
Ceiling Bracket M6 100 cm	10800002	10800005		Compact Electrol, ProScreen CSR, ProScreen, SlimScreen
Ceiling Bracket Elpro Large Electrol 100 cm	10800094			Tensioned Elpro Large Electrol, Elpro Large Electrol
Ceiling Bracket Master Electrol 100 cm			10800078	Master Electrol



Soffit Bracket

Bracket for making the mounting of a projection screen into a soffit easy. With the Soffit Bracket the points of suspension are moved to the side of the case making it easy to mount the projection screen, even in a narrow soffit.

Bracket (Aluminium)	Product Code	Available for
Soffit Bracket	10800089	Compact Electrol, Hapro CSR, ProScreen CSR, ProScreen
Soffit Bracket Elpro Large Electrol	10800093	Tensioned Elpro Large Electrol, Elpro Large Electrol



BrightSight

BrightSight is composed of a special mixture of mild cleaning ingredients based on alcohol and is the first cleaning system for projection screens which is both effective and safe. Simply spray a small amount of BrightSight on to the screen. Clean horizontally with a clean cloth and you're done. BrightSight offers ideal protection for every valuable projection screen fabric. With BrightSight, Projecta offers a unique cleaning solution to extend the life of each projection screen. Make sure the material is dry before storing or retracting the surface.

Type	Product Code
1 × 0.75 l BrightSight	10800998
3 × 0.75 l BrightSight	10800999
12 × 0.75 l BrightSight	10800997

Screen Bag

Protective cover protects the tripod screen from dust and prevents damage during transportation.



Type	Product Code
Screen width 127 - 152 cm	10830043
Screen width 178 cm	10830045
Screen width 213 cm	10830046
Screen width 244 cm	10830047

Da-Lite Projection Screens



FOR YOUR IMAGE™



Large venue projection screens



74

Arena Electrol



75

Studio Electrol



76

GiantScreen
Electrol

Fixed frame projection screens



77

Wireline Advantage

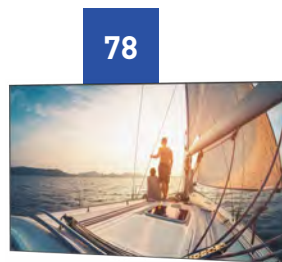

78

UTB Contour



79

Series 200 / 300

Rear projection screens



80

Flex Plex



81

Holo Screen



Matte White
Viewing Angle: 100°
Gain: 1.0

Matte White Sound
Viewing Angle: 100°
Gain: 1.0

Retrotex
Viewing Angle: 60°
Gain: 0.5

Other

Available dimensions

Minimum width: 5 m

Maximum width: 14 m

Maximum height: 8 m

Other options

- Available with a RF motor (remote control) and with a non-RF motor (wall switch). Request a non-RF motor for connection to an AV control system.



Arena Electrol

The Arena Electrol is the solution to your large venue motorized projection screen needs.

- Robust case with a powerful motor and Polichinelle, which is a unique motorized cable and pulley system.
- The Polichinelle system guarantees a safe, taut and horizontal screen projection surface even in the largest sizes.
- The case and the projection screen surface can be made to exactly the right size.
- Available with Matte White or Matte White Sound projection screen surfaces.
- The Arena Electrol is supplied with a RF remote control as standard.
- The screen is mounted using mounting brackets on the top or to the rear of the case. Depending on the length of the case, the screen is supplied with up to four brackets.
- Also available with a rear projection screen surface in addition to Matte White. The seam in the rear projection screen surface may be slightly visible under projection.
- The motor is equipped with electric locks to prevent inadvertent unrolling and features thermal overload cut-off.

Polichinelle System

In a standard projection screen, the weight of the slat bar, along with other elements, ensure that the projection screen surface remains properly tensioned. The Polichinelle system reverses the usual situation to achieve the correct tension. With this system, the projection screen surface rolls up around the slat bar which is retracted by two steel cables. This system can be adjusted both in the case and the slat bar, ensuring that the projection screen surface is smooth and taut under tension. The Polichinelle System ensures the flattest possible screen surfaces for sizes over 8 meters wide and is the ideal choice for auditoriums, theaters and other large venues.

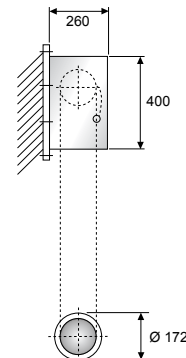

Dimensions and product codes on

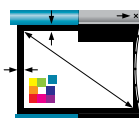

100



Customise this projection screen to perfectly fit your installation

Matte White projection surface in this projection screen is a vinyl based material without black backing.



-  **Matte White**
Viewing Angle: 100°
Gain: 1.0
-  **Matte White Sound**
Viewing Angle: 100°
Gain: 1.0
-  **Retrotex**
Viewing Angle: 60°
Gain: 0.5



- 16:10**
- 4:3**
- Other**

Available dimensions
 Minimum width: 7 m |
 Maximum width: | 10 m
 Maximum height: 6 m

Studio Electrol

The Studio Electrol is ideal for large screen applications including auditoriums, stages, arenas and multi-purpose rooms.

- Robust case with a powerful motor.
- Limit switches are factory set guaranteeing a long life span. The Studio Electrol is supplied with a wall switch.
- The screen is mounted using four flexible mounting brackets on the top or to the rear of the case.
- The motor is equipped with electric locks to prevent inadvertent unrolling and features thermal overload cut-off.
- The underside of the case is open as standard. A closed version can be supplied at additional cost.
- Also available with a rear projection screen surface in addition to Matte White.
 The seam in the rear projection screen surface may be slightly visible under projection.
- The case and the projection screen surface can be made to exactly the right size.



Aluminium case

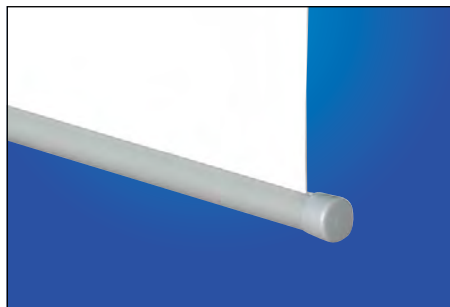

Rounded slat bar

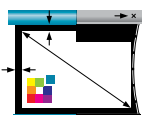
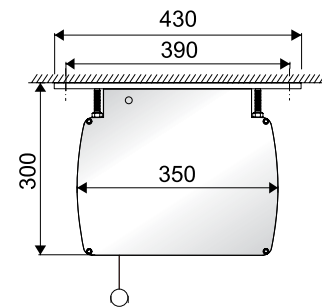

Customise this projection screen to perfectly fit your installation



Matte White projection surface in this projection screen is a vinyl based material without black backing.

Dimensions and product codes on **100**



Matte White
Viewing Angle: 100°
Gain: 1.0

Matte White Sound
Viewing Angle: 100°
Gain: 1.0

Retrotex
Viewing Angle: 60°
Gain: 0.5



16:10

4:3

Other

Available dimensions

Minimum width: 5 m |

Maximum width: | 7 m

Maximum height: 5 m

GiantScreen Electrol

The first choice for medium to large size venues.

- Robust case with a powerful motor.
- Limit switches are factory set guaranteeing a long life span. The GiantScreen Electrol is supplied with a wall switch.
- The projection screen is mounted to the wall and/or ceiling using three brackets which can be positioned flexibly. The brackets can be positioned up to one meter from each side.
- The motor is equipped with electric locks to prevent inadvertent unrolling and features thermal overload cut-off.
- The underside of the case is open as standard. A closed version can be supplied at additional cost.
- Also available with a rear projection screen surface in addition to matte white. The seam in the rear projection screen surface may be slightly visible under projection.
- The case and the projection screen surface can be made to exactly the right size.



Robust case



Adjustable mounting brackets

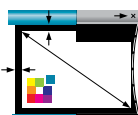
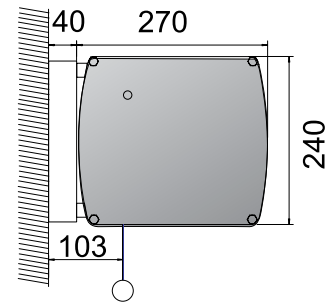

Customise this projection screen to perfectly fit your installation







Matte White projection surface in this projection screen is a vinyl based material without black backing.

Dimensions and product codes on

100



HD PROGRESSIVE

-  **HD Progressive 0.6**
Viewing Angle: 170°
Gain: 0.6
-  **HD Progressive 0.9**
Viewing Angle: 170°
Gain: 0.9
-  **HD Progressive 1.1**
Viewing Angle: 170°
Gain: 1.1
-  **HD Progressive 1.3**
Viewing Angle: 150°
Gain: 1.3
-  **Dual Vision**
Viewing Angle: 130°
Gain: 0.9



16:10

16:9

Available dimensions

Minimum width: 300 cm |
Maximum width: | 488 cm



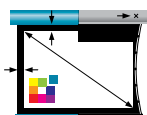

Wireline Advantage

- Designed for large venues, the Wireline Advantage uses thin steel cables up to 8.8 meters instead of black drop to lower the screen to an appropriate viewing height.
- The Advantage line of projection screens is designed with ceiling trim in place. Once the screen is installed, the screen trim conceals the rough opening.
- Sliding installation brackets make it easy to attach the screen housing to the structure above the drop ceiling.
- Available without trim flange for non-ceiling recessed applications
- Tensioning Cable System to prevent warping and ensure even lateral tension. Tensioned screens ensure the smoothest surface possible
- Standard with radio frequency motor and hand-held remote. Optional radio frequency control accessories include single channel wall switch, dry contact interface, and RS-232 interface
- Seamless projection surfaces in all models.



Customise this projection screen to perfectly fit your installation



-  **HD Progressive 0.6**
Viewing Angle: 170°
Gain: 0.6
-  **HD Progressive 0.9**
Viewing Angle: 170°
Gain: 0.9
-  **HD Progressive 1.1**
Viewing Angle: 170°
Gain: 1.1
-  **HD Progressive 1.3**
Viewing Angle: 150°
Gain: 1.3



- 16:10**
- 16:9**

Available dimensions

Minimum width: 203 cm |
Maximum width: | 488 cm

HD PROGRESSIVE

UTB Contour

The UTB Contour is a fixed frame screen that features an ultra-thin bezel frame and low profile.

- Designed to look like a large flat panel, the UTB Contour can more than double the size of the largest flat panel televisions available.
- The UTB Contour has the smallest edge (6 mm) of any fixed frame on the market.
- Low profile flat panel design – 3.5 cm off the wall.
- The UTB Contour features the latest technology in projection surfaces to maximize the technology of your projector, HD Progressive designed for 1080p, 4K and Ultra HD.
- Standard black backing retains projected brightness and seamless in all sizes.

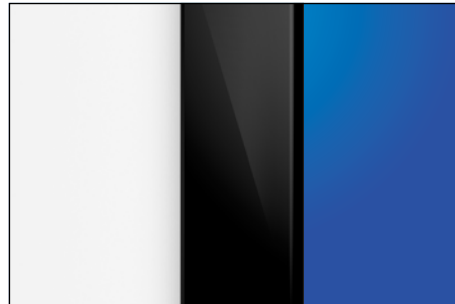

Smallest edge in the market



Low profile installation

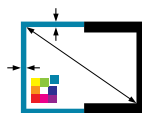

Customise this projection screen to perfectly fit your installation



Other

Available dimensions

Minimum width: 12 m |
Maximum width: | 40 m

Series 200 / 300

Heavy duty lace and grommet tensioned screen up to 40 metres wide in front projection and 12 metres wide in rear projection, either straight or curved.

- The screen's robust tubular frame construction keeps the fabric taut, making it possible for the screen to be suspended freely from a truss construction for large events.
- The screen is also well suited for wall mounting and can even be mounted on legs.
- The Series 200 and 300 will be customised to project specifications.
- The curved version can be supplied with any degree of curvature based on a single axis.
- Suitable for any situation requiring special projection solutions, including custom shapes and sizes such as circles, trapezoid shapes and triangles.
- The frame can be attractively finished with a black velvet edging, whereby the black velvet prevents reflection and serves to absorb projected light.
- The frame is constructed of aluminium tubing with pre-mounted and pre-positioned tensioning cords and "S" hooks for easy mounting which are concealed by the velvet edging.
- The tubing diameter for the Series 200 is 5.1 cm with screens available up to a width of 9 metres.
- The tubing diameter for the Series 300 is 7.6 cm with screens available up to a width of 40 metres.
- The curved Series 200 or 300 is ideal for simulation and demonstration applications.
- The screen can be optionally packed in robust plastic travel cases on wheels.

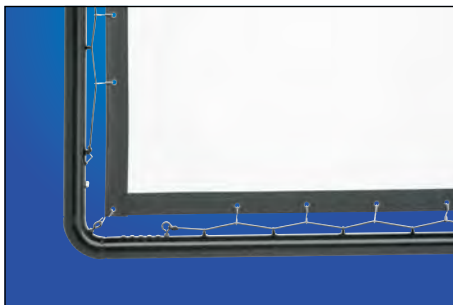

Robust tubular frame construction

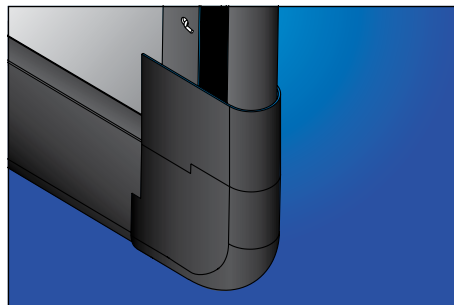

The frame can be finished with a black velvet edging

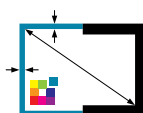

Customise this
projection screen
to perfectly fit
your installation



DA-100
Viewing Angle: 70°
Gain: 1.0

DA-130
Viewing Angle: 68°
Gain: 1.3

DA-150
Viewing Angle: 64°
Gain: 1.5

DA-180
Viewing Angle: 60°
Gain: 1.8

DA-230
Viewing Angle: 50°
Gain: 2.3



DA-50 WA
Viewing Angle: 120°
Gain: 0.5

DA-75 WA
Viewing Angle: 156°
Gain: 0.75

DA-100 WA
Viewing Angle: 104°
Gain: 1.0

16:10

16:9

Available dimensions

Maximum width: 792 cm

Maximum height: 277 cm

Flex Plex

- Flex Plex is an easy transportable and roll-able solution for in-wall installations. FlexPlex is designed for applications that cannot accommodate a large crate.
- The Flex Plex is an acrylic, lightweight rear projection screen that ships in a roll.
- Coatings are permanently bonded to the substrate and cannot peel off.
- Select the optical coating that best suits your installation. Please note that with high resolution projection we recommend the wide angle (WA) coatings.
- The substrate has an optical coating on one surface that does not exceed 0.1 mm in thickness.
- Acrylic screen materials offer high resolution diffusive reflection for permanent installations.
- The thin diffusion coating is permanently bonded to the acrylic substrate and cannot peel off like laminated film or vinyl based diffusion screens.
- Acrylic substrate for breakage resistance, lightweight, high optical quality, ease of handling and superior transmission.
- The screen substrate is made of a clear acrylic plastic.
- Ships in a roll and Includes frame, mounting t-track and trim.

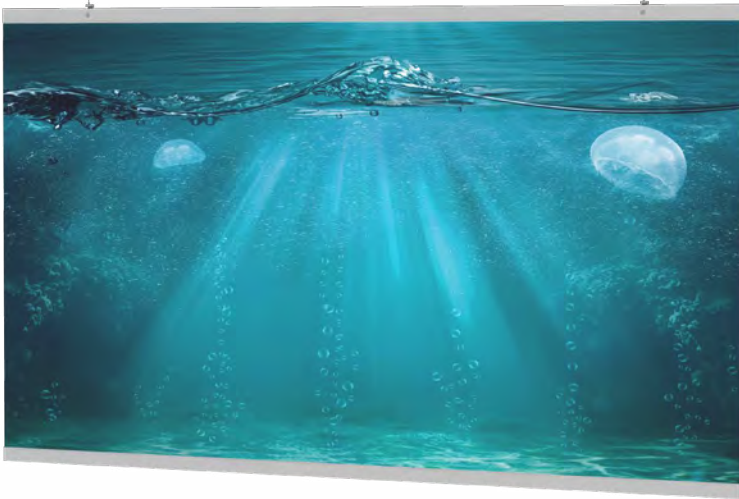

Other
Available dimensions

Maximum width: 762 cm

Maximum height: 277 cm

Holo Screen

The Holo Screen is designed for point-of-sale applications in retail stores, window displays, airports, banks and other high traffic areas.

- The transparent display allows viewers to look at and see through the screen.
- The Holo Screen is a single piece acrylic rear projection screen with a specially designed optical coating. This optical coating bonds to the acrylic so it will not crack, peel or become discolored.
- The Holo Screen features an advanced holographic technology that displays images rear projected from 18-35 degrees. The result is a remarkably bright and clear image - even in brightly lit environments.
- The Holo Screen is available in custom sizes up to 277 cm height and 762 cm width.
- The Holo Screen includes an aluminum extruded top and bottom frame for ease of installation. Adjustable and lockable fasteners and stainless steel cables complete the installation.

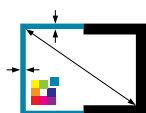

Customise this
projection screen
to perfectly fit
your installation



DA-LITE impressions

Glossary

Active 3D

Active 3D involves a single projector rapidly alternating between displaying the left eye image and the right eye image. The frequency is coordinated with a pair of shuttered glasses which block the light to the opposite eye at the same rate. With active 3D it isn't necessary to use a projection surface with polarisation retention.

Ambient Light

Ambient light is the amount of unwanted light in a room that can affect the projection in a negative way. Ambient light can come from windows or from room lighting.

ANSI-Lumen

Lumen is the unit of luminous flux, a measure of the power of light perceived by the human eye and the light output of projectors. The unit of measure is Lumens. The standardization for this measurement has been established by the American National Standards Institute (ANSI).

Aspect Ratio

An aspect ratio is the relationship between the width and height of an image. Common aspect ratios are Video (4:3), HDTV (16:9), Wide (16:10), Cinemascope (2.35:1) and Square (1:1).

Black Drop

Black Drop is the extended black border above the viewing area used to position the viewing area at the appropriate height.

Brightness

Brightness is an attribute of visual perception in which the projection screen reflects light.

Contrast

Contrast is the difference between the brightest white and the darkest black.

Easy Serviceability System

The motor and screen surface of the projection screen are accessible for maintenance and service without uninstalling the screen casing.

Edge Blending

A setup with multiple projectors projecting a single source creating a single image.

Gain

Gain is a measure of reflection performance. Gain is related to a universal reference standard: Magnesium Carbonate ($MgCO_3$). Rather than absorbing light, $MgCO_3$ reflects projected light back with perfect evenness.

Hot Spot

A hot spot occurs when the light of the projector is centered on the projection screen creating a brighter area. Hot spotting is the opposite of uniform projection.

IR: Infrared

Wireless control via Infrared wavelengths are used to operate the projection screen. The receiver has to be placed into sight of the remote control.

Keystone Correction

Distortion created by the angle of the projected image can be corrected by tilting the angle of the projection screen.

LUX

Lux is the perceived amount of light that is reflected by the projection screen.

Overall Dimensions

The overall dimensions of a projection screen are the dimensions of the projection surface including the borders.

Passive 3D

Passive 3D uses polarising filters and a projection surface with polarisation retention to separate the two different signals. Passive 3D is often realised using two projectors, one for each eye's information.

Potential Free Contacts

Potential free contacts refer to a contact of a relay which does not make or break a current. Usually some other relay or device has the job of starting or stopping the current.

RAL

RAL is a colour matching system used in Europe.

RF: Radio Frequency

Wireless control via Radio Frequency is used to operate the projection screen. The receiver can be placed out of sight of the remote control. The range of RF is 20 metres through walls.

RS232

Recommended Standard 232 is a standard for serial binary data and control signals commonly used in computer serial ports.

Tab-Tensioned

Parabolic curves on both the left and right side enable a vinyl front or rear projection screen surface to be perfectly flat and retractable. The parabolic curves are calculated in relationship to the size of the screen. Tab-tensioning allows for the flattest possible projection screen surface in a retractable screen.

Uniformity

An even distribution of light on a projection screen. Uniformity is essential for an even image with a wide viewing angle in the desired direction.

Viewing Angle

The viewing angle of a projection screen fabric indicates the maximum angle at which the projected image is still clearly visible.

Viewing Area

The viewing area of a projection screen is the available area for projection within the borders.



PROJECTA[®]

REFLECTING YOUR VISION | legrandav.com

T +31 (0) 495 580 840 F +31 (0) 495 580 845 E av.emea.sales@legrand.com
Franklinstraat 14, 6003 DK Weert, P.O. Box 191, 6000 AD Weert, The Netherlands

©2018 Milestone AV Technologies. 180344 11/18 Projecta is a registered trademark of Milestone AV Technologies. All other brand names or marks are used for identification purposes and are trademarks of their respective owners. All patents are protected under existing designations. Other patents pending.

A brand of  **legrand**[®]

AV Brands Chief | Da-Lite | Middle Atlantic | Projecta | Sanus | Vaddio