

The image features a dark brick wall background. In the center, the word "ClearOne" is written in a bold, white, sans-serif font with a black outline. The text is surrounded by abstract, colorful paint splatters in shades of pink, orange, and grey. A registered trademark symbol (®) is located to the right of the word. Below the logo, there is a blue rectangular box containing the text "Products - introduction" in white.

ClearOne®

Products - introduction

Unified
Communications



BYOD
conferencing



Media
collaboration



Wireless
microphones



Wired
microphones



Digital Sound
Processors

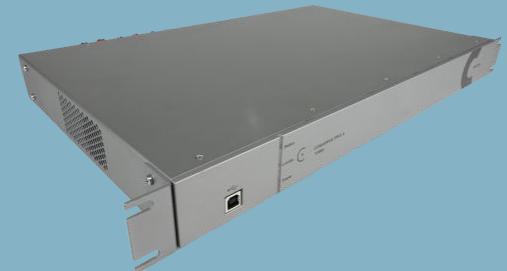

The image features a brick wall background with a large, stylized logo for 'ClearOne'. The logo consists of the word 'ClearOne' in a bold, white, sans-serif font with a black outline. The letters are set against a dark, irregular shape that resembles a speech bubble or a stylized 'C'. This shape is surrounded by various graffiti-style elements, including splatters of pink, orange, and blue paint, and abstract brushstrokes in black and white. A registered trademark symbol (®) is visible to the right of the word 'One'.

ClearOne®

Unified Communications

- ClearOne offers cameras for collaboration and conferencing.
- Unite 20 - FullHD, USB 2.0, 120-degrees field of view,
- Unite 50 - 4K resolution, electronic PTZ, 120-degree lens, Zoom-certified
- Unite 150/200 - PTZ cameras, 255 presets, Zoom-certified



- Speakerphones with echo cancellation, First Microphone Priority from 1-2 users to 15-16 people in one room.



- Versa 50/150 for PC - compatible with any application: Zoom, Webex, MS Teams etc.
- Included: 4K or FullHD camera, Chat 150 speakerphone and Versa hub.
- Versa hub allows one USB 3.0 cable connectivity to PC, supports 2 monitors (for video and presentation), Ethernet network pass-through for laptop.
- Daisy-chain another Chat 150 for a room of up to 15-16 people.



CONVERGE Huddle for huddle rooms

ClearOne[®]

- Huddle - a small sound mixer with PC connectivity, HDMI output, camera input.
- Perfect for small and medium-sized rooms.
- Support for any video application on PC or local presentations.

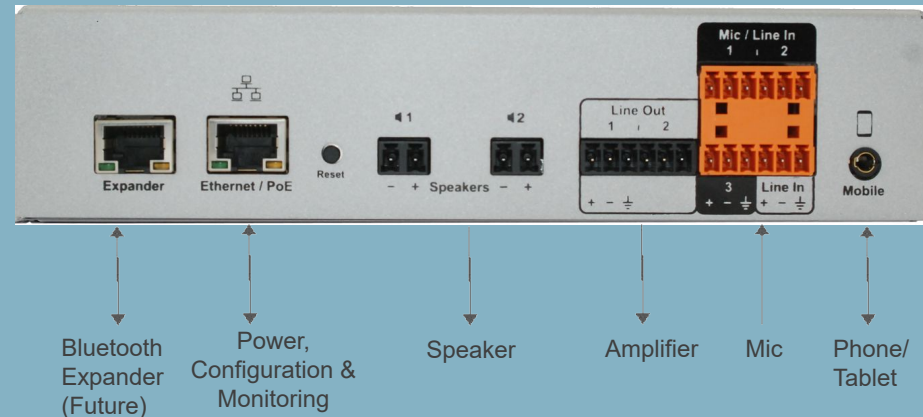
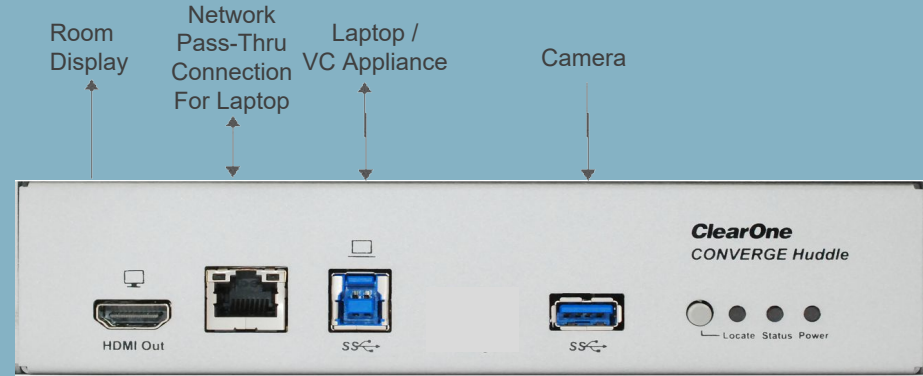

- Versa Pro 50 - a ready-to-use bundle for all PC-based collaboration and local presentations.
- Includes: Unite 50 camera (4K resolution, ePTZ, 120-degree field of view), ceiling microphone, Converge Huddle DSP.
- Perfect for smaller rooms - up to 12 people.
- A very competitive price.



- Versa Pro 150 - connect your laptop for collaboration or local presentations in a medium-sized conference room
- Includes: Unite 150 camera (12x optical zoom, 72.5-degree field of view, 255 presets), ceiling microphone, Converge Huddle



- Versa Pro CT - Huddle with the BMA CTH drop-ceiling microphone.
- Just add a Unite 50/150 camera and loudspeakers (8 Ohm).
- Loudspeakers can be connected to BMA CTH as it has a built-in amplifier.
- 3 months of free Collaborate Space collaboration system, but also works with any PC application.
- Works great with Bluetooth Expander.
-

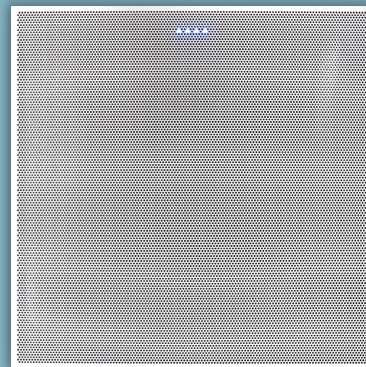

- + Pair your phone or tablet with Converge Pro 2 or Huddle.
- + Bi-directional Bluetooth 3.0 connection - you will speak to Converge Pro 2 / Huddle microphones and hear from loudspeakers instead of the phone / tablet.
- + You can bridge your phone call with the videocall on your PC.
- + Pair via NFC or traditional Bluetooth.
- + Range up to 45 meters.



CONVERGE Huddle for audio conferencing

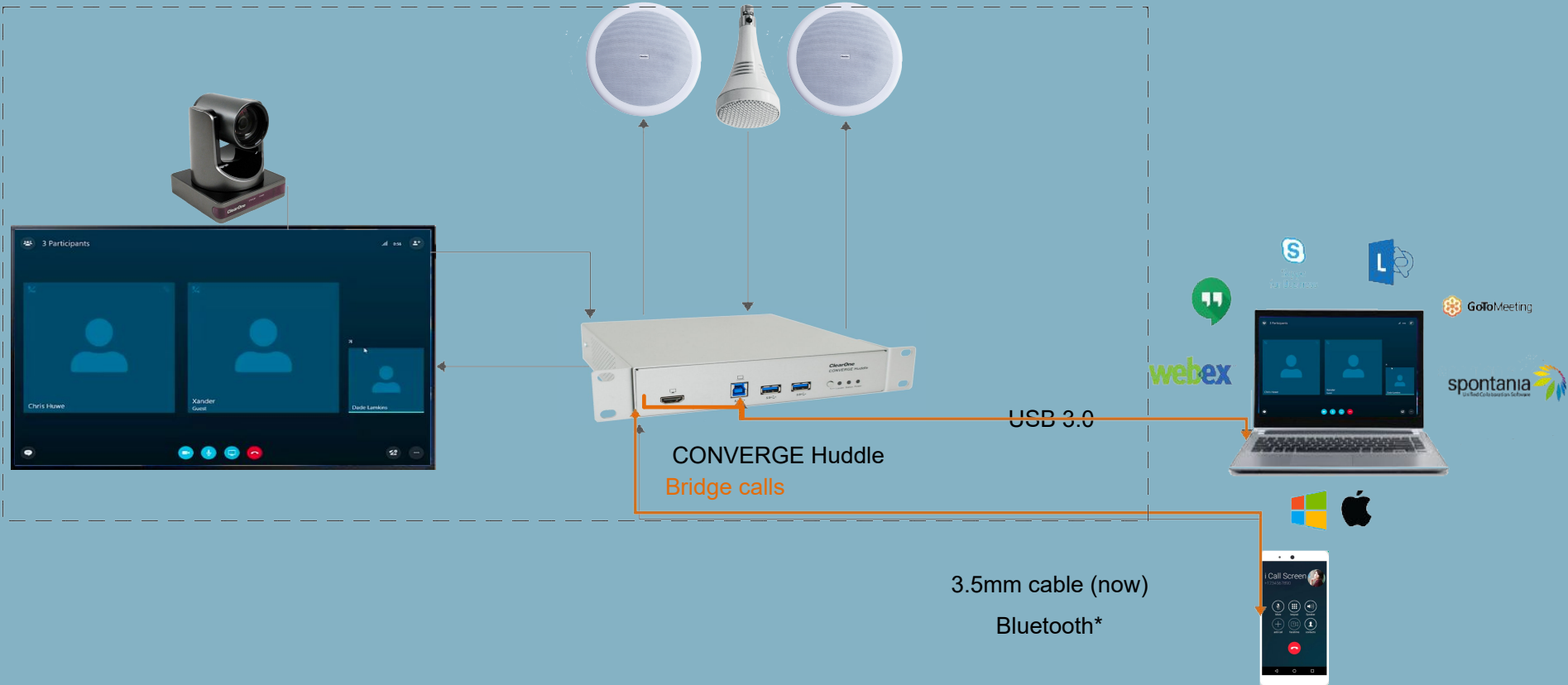

Versa Lite CT - ceiling tile mic with USB connectivity

- + Ceiling tile beamforming microphone with USB connectivity.
- + No DSP required => much lower costs.
- + Audio processing - on the BMA CT.
- + Add loudspeakers - directly to the BMA
- + Add a ClearOne Unite camera and a Bluetooth Expander (optionally)
- + Connect to a PC or a USB hub.
- +

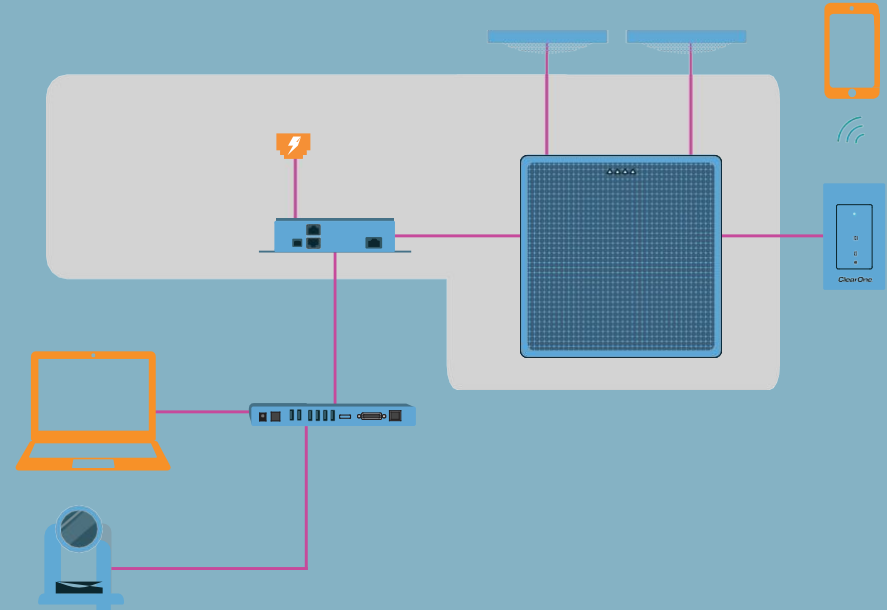

Versa Room CT - just connect a PC

- + The USB-enabled ceiling tile beamforming microphone with all accessories
- + Includes: BMA CT, USB adapter, 2 ceiling speakers, Versa hub, Unite 50 4K camera
- + No DSP required => much lower costs.
- + Connect to a PC or video terminal.
- + Add a BT Expander optionally.
- +

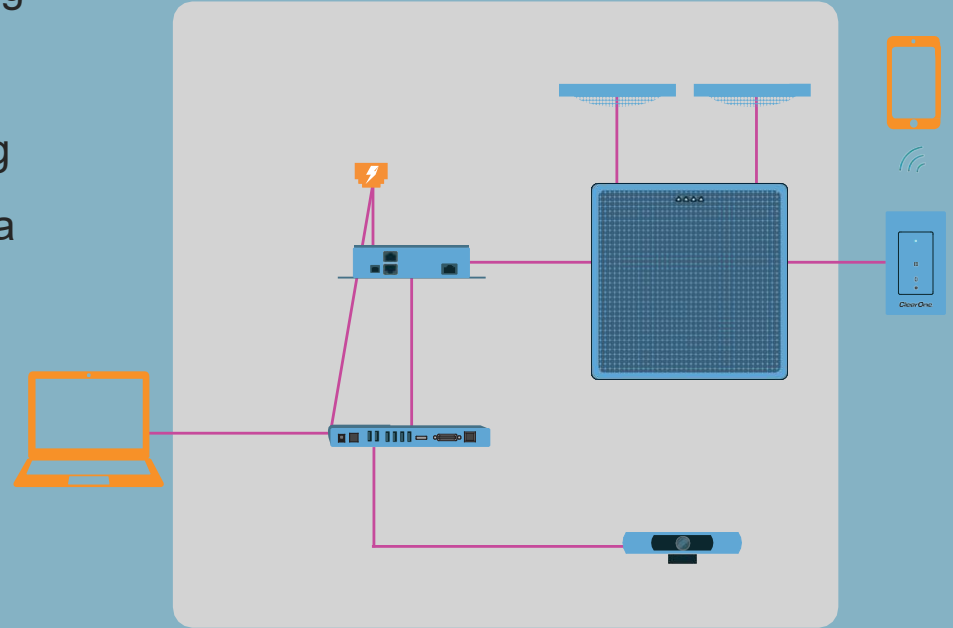

Certified by Barco for ClickShare Conference

- + The following products are endorsed as “Compatible with ClickShare Conference” by Barco so you can confidently offer them with a ClickShare solution:
- + COLLABORATE Versa Lite CT
- + COLLABORATE Versa Room CT
- + COLLABORATE Versa Pro CT
- + COLLABORATE Versa Pro 150
- + COLLABORATE Versa Pro 50
- + COLLABORATE Versa 150
- + COLLABORATE Versa 50
- + UNITE 20 Pro WebCam
- + UNITE 50 4K ePTZ HD Camera
- + UNITE 150 PTZ Camera
- + UNITE 200 PTZ Camera

Compatible with
ClickShare
Conference

BARCO

The image features a dark brick wall background with colorful graffiti in shades of pink, orange, and grey. The word "ClearOne" is written in a bold, white, sans-serif font with a black outline, positioned centrally. A registered trademark symbol (®) is located to the right of the word. Below the logo, a blue rectangular box contains the text "Video conferencing" in white, bold, sans-serif font.

ClearOne®

Video conferencing

- Live 200 - for rooms up to 6-8 people, terminal SIP/H.323, 4K camera, Chat 150 speakerphone
- Live 300 - for rooms up to 6-8 people, terminal SIP/H.323, FullHD camera with 12x optical zoom, Chat 150 speakerphone
- Live 600 - up to 15-16, terminal SIP/H.323, built-in MCU expandable to 9 locations, FullHD camera with 12x optical zoom, Chatattach 150 speakerphone
- Live 900 - up to 25 people, terminal SIP/H.323, built-in MCU expandable to 9 locations, FullHD camera, Converge Pro 48V/T DSP and BFM 2 microphone array
- Live 1000 - Live 900 with BMA Ceiling Tile microphone array

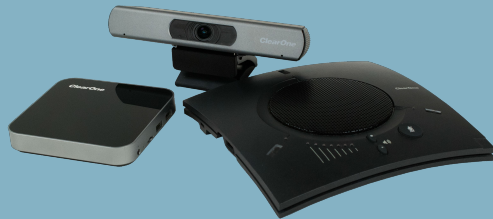

The image features a dark brick wall background. In the center, the word "ClearOne" is written in a bold, white, sans-serif font with a black outline. The text is surrounded by abstract, colorful paint splatters in shades of pink, orange, and grey. A registered trademark symbol (®) is located at the end of the word. Below the main text, there is a blue rectangular box containing the text "COLLABORATE Space" in white, bold, sans-serif font.

ClearOne®

COLLABORATE Space

- COLLABORATE Space is a suite with a full suite of audio, video and meetings tools.
- It connects hundreds of users for voice and video calls, channels, chats, file sharing.
- In meetings participants can share data, chat, record sessions, use an interactive whiteboard and annotations.
- COLLABORATE Space allows phone calls to any phone number in the world directly from the application and even bridge them into meetings.
- Support for legacy systems with SIP/H.323 gateway connections.
- webRTC access for all popular web browsers - no need to install any plug-ins.
- Capability to initiate Space meetings directly from MS Teams.

- COLLABORATE Space is available as a cloud-based service or on-premise.

Features	Basic	Pro	Enterprise
Participants per Room	50 (25 video/25 audio)	50 (25 video/25 audio)	50 (25 video/25 audio)
IM and Presence	yes	yes	yes
Recording	yes	yes	yes
H.323/SIP Gateway	optional, up to 16	yes, up to 16	yes, up to 16
Outbound Telco Calls	yes	yes	yes
Channels (persistent space)	no	yes	yes
Included Cloud Storage	2 GB	5 GB, can buy more	yes
Classroom	yes	yes	yes
Webinar	no	yes	yes
Cloud / On-premise Server	cloud	cloud	on premise

➤ Classroom or Webinar are available as extension to Space Basic, Pro and Enterprise.

Features	Meetings	Classroom	Webinar
Participants per Room	100	100/200/300/500	500/1000
Max. No Of Video Screens	49	10	10
Max. No of Avatars on Display	100	25 (If participant's audio enabled)	
Recording	yes	yes	yes
Sharing/Whiteboard	Yes	Yes (after host enables)	Yes (after host enables)
Share video file	yes	Yes (after host enables)	Yes (after host enables)
Chat	yes	yes	no
Access to Agenda, Notes, Attachments, Tasks etc..	yes	yes	only agenda
Hand Raise Feature	no	yes	yes
Questions And Answers	no	yes	yes
Mute all camera/mic by host/presenter	yes	yes	no

A graffiti-style logo for 'ClearOne' is painted on a dark brick wall. The word 'ClearOne' is written in a bold, white, italicized sans-serif font with a thick black outline. The letters are set against a background of abstract, colorful brushstrokes in shades of pink, orange, grey, and white. The overall style is urban and artistic.

ClearOne®

CONVERGE® Pro 2

- + Sound processors to connect multiple sources to multiple outputs.
- + Sources: microphones, video terminals, PCs, media players etc.
- + Outputs: amplifiers, PCs, recorders, loudspeakers.
- + Superb audio processing for local reinforcement, audio conferencing, video conferencing etc.
- + Superb platform for peripherals such as beamforming microphones, wireless microphones.
- + Users can even manage lights from Converge Pro 2, combine / divide rooms etc.

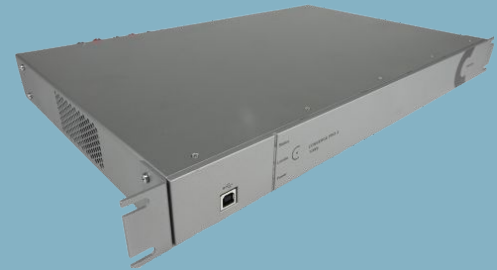

Solution	Product	Mic/Line Inputs	Mic/Line Outputs	AEC	USB	VoIP / S4B	Telco	Dante
Conferencing	CONVERGE Pro 2 128	12	8	✓	✓	--	--	--
	CONVERGE Pro 2 128D	12	8	✓	✓	--	--	✓
	CONVERGE Pro 2 128VT (New)	12	8	✓	✓	✓	✓	--
	CONVERGE Pro 2 128VTD (New)	12	8	✓	✓	✓	✓	✓
	CONVERGE Pro 2 128T	12	8	✓	✓	--	✓	--
	CONVERGE Pro 2 128TD	12	8	✓	✓	--	✓	✓
	CONVERGE Pro 2 128V	12	8	✓	✓	✓	--	--
	CONVERGE Pro 2 128VD	12	8	✓	✓	✓	--	✓
	CONVERGE Pro 2 48VT (New)	4	8	✓	✓	✓	✓	--
	CONVERGE Pro 2 48VTD (New)	4	8	✓	✓	✓	✓	✓
	CONVERGE Pro 2 48T	4	8	✓	✓	--	✓	--
	CONVERGE Pro 2 48V	4	8	✓	✓	✓	--	--

CONVERGE® Pro 2 – Scalable with flexible connectivity **ClearOne**

- + Stack up CP2 units together up to 144 mic/line inputs (or 12 units)
- + One Converge Pro 2 can manage several rooms as separate zones with independent resources (microphones, loudspeakers, VoIP lines, USB ports for PCs)
- + New expansion bus “**C-Link**” between Converge Pro 2 at 45-meter distance
- + New peripheral bus “**P-link**” to connect - 60 meters between devices (microphones, USB expanders, Bluetooth Expander etc.)



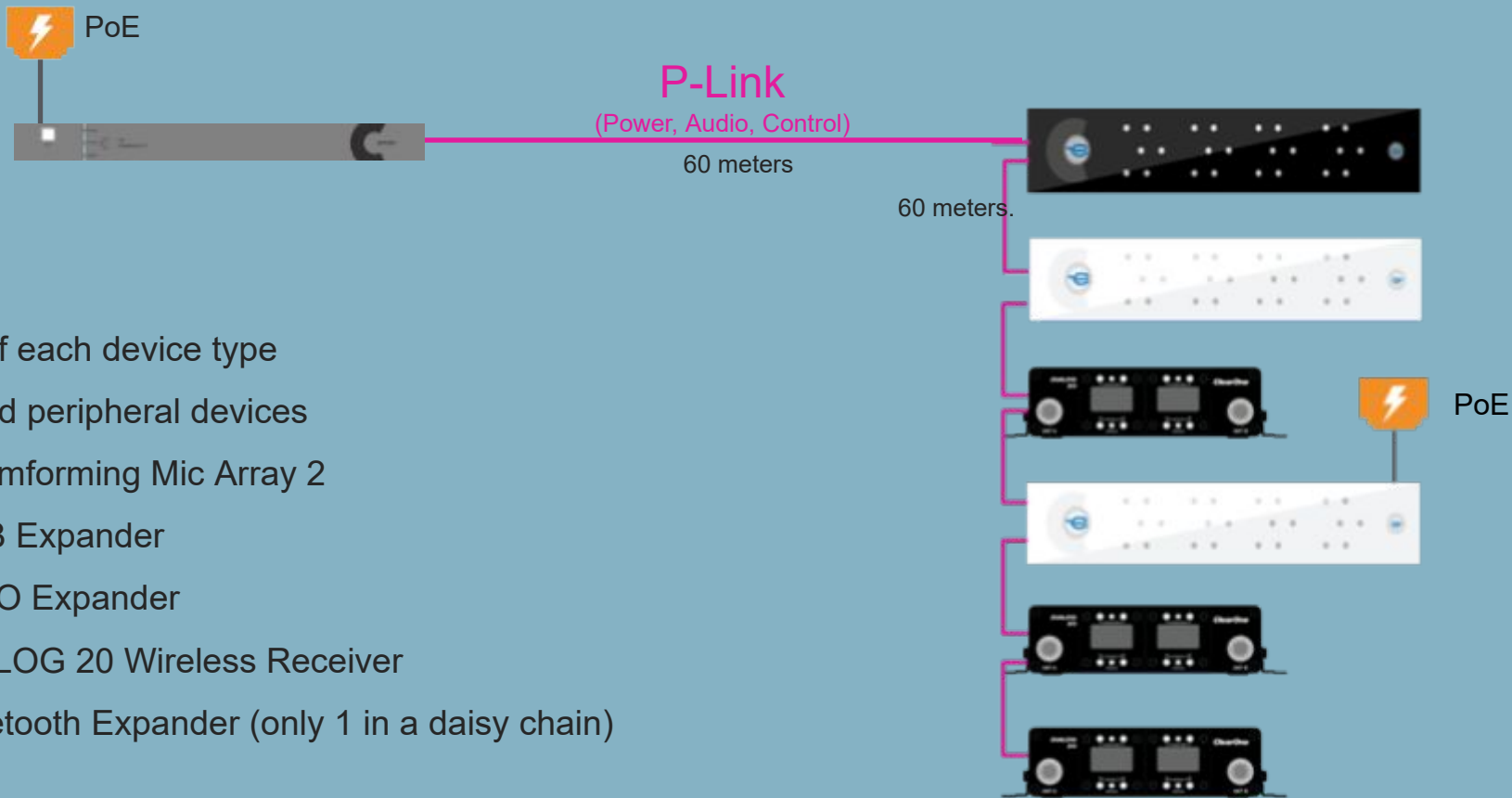

- + Up to 3 of each device type
- + Supported peripheral devices
 - Beamforming Mic Array 2
 - USB Expander
 - GPIO Expander
 - DIALOG 20 Wireless Receiver
 - Bluetooth Expander (only 1 in a daisy chain)

CONVERGE® Pro 2 Shared with USB Audio



Room 1



USB Cable (5m)

Converge Pro 2



Room 2



USB Cablet (5m)



USB Expander

Room 3



USB Cable (5m)



USB Expander

Room 4



USB Cable (5m)



USB Expander

200 ft.
(60m)

200 ft.
(60m)

200 ft.
(60m)

- + Superior performance with most advanced echo cancellation, noise cancellation up to 25 dB.
- + Support for both small systems (one mixer for several rooms) and large systems (up to 12 mixers in one stack).
- + Multiple VoIP lines for independent calls.
- + Optimized to work with Beamforming Mic Array, BMA CT and DIALOG 20 Wireless Mics.
- + Management via Touch Panel Controller or a free Dialer application (Windows/MacOS/Android/iOS).

Beamforming Microphone Array 2

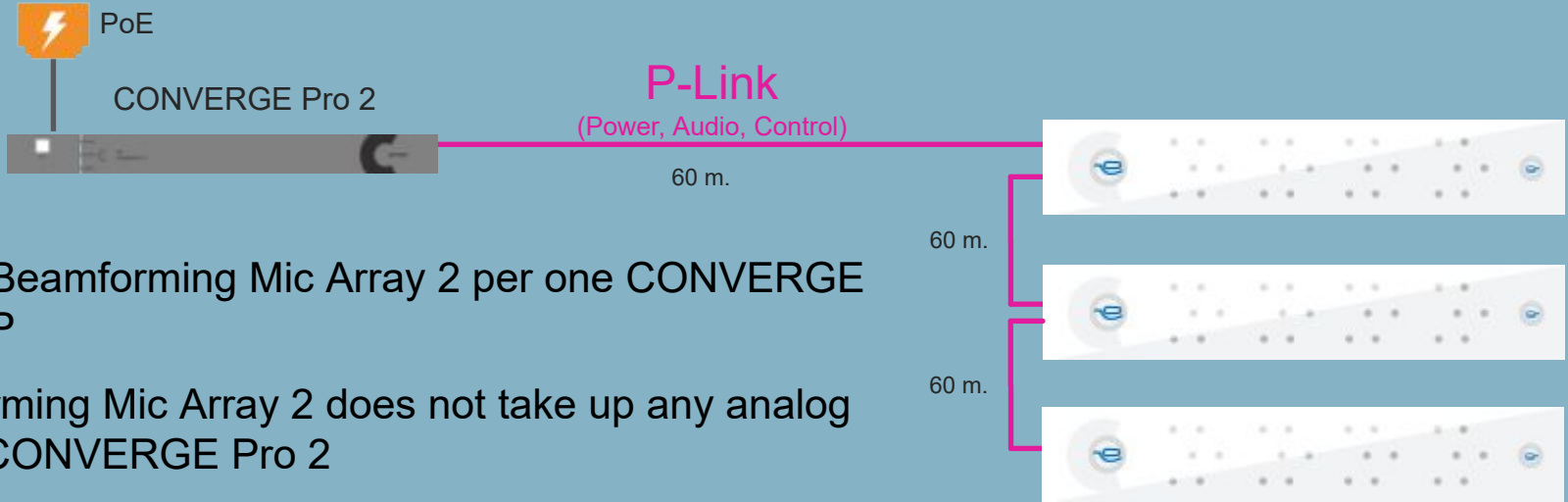

+Up to 3 Beamforming Mic Array 2 per one CONVERGE Pro 2 DSP

+Beamforming Mic Array 2 does not take up any analog ports on CONVERGE Pro 2

+BMA sets up an acoustic beam towards the speaker while the speaker can move around the conference room

+200 meters between BMA 2 when only BMA 2 connected

- + Daisy chain up to 3 BMA CTs to one Converge Pro 2 DSP.
- + BMA Ceiling Tile supports a long-distance P-Link mode - up to 200 meters between a DSP and a microphone and between microphones.
- + Built-in amplifier 2 x 10 Watt allows to connect loudspeakers directly to BMA CT.
- + Drop ceiling grid ready - 600 mm x 600 mm, 625 mm with adapter
- + Available hard-ceiling mounting options (surface, recessed installations) as well as a VESA mount bracket.

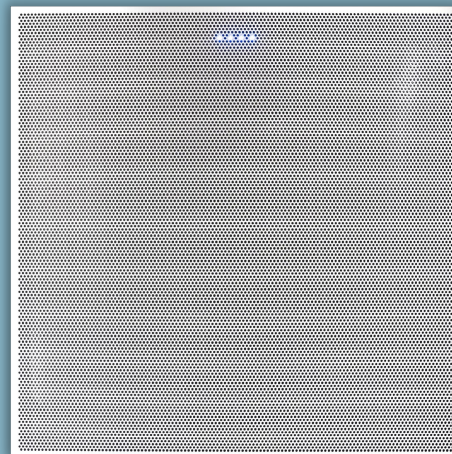

- + BMA 360 - The world's first truly wideband, frequency invariant beamforming mic array with uniform gain response across all frequency bands
- + 6th generation Acoustic Echo Cancellation (AEC)
- + On-board audio algorithms, like noise reduction, filtering, and Automatic Level Control, eliminate the need for per-beam processing in a DSP mixer - requiring fewer DSP mixer resources.
- + Camera tracking possible with beam reports.
- + Built-in amplifier 4x15W (2 x 30 Watt bridged) allows to connect loudspeakers directly to BMA 360.

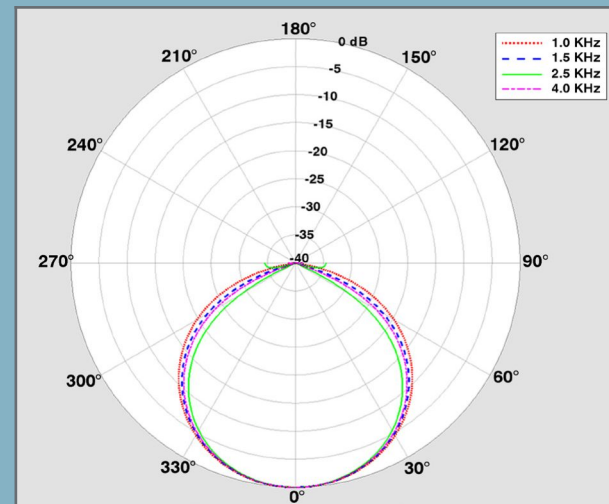
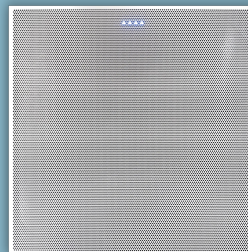

- + Easy adjustment to room sizes.
- + Daisy chain up to 3 BMA 360 to one Converge Pro 2 DSP.
- + Drop ceiling grid ready - 600 mm x 600 mm, 625 mm with adapter

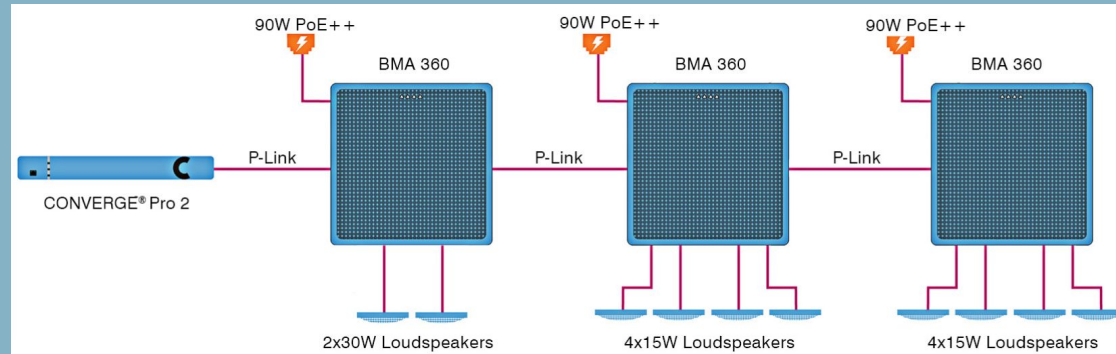
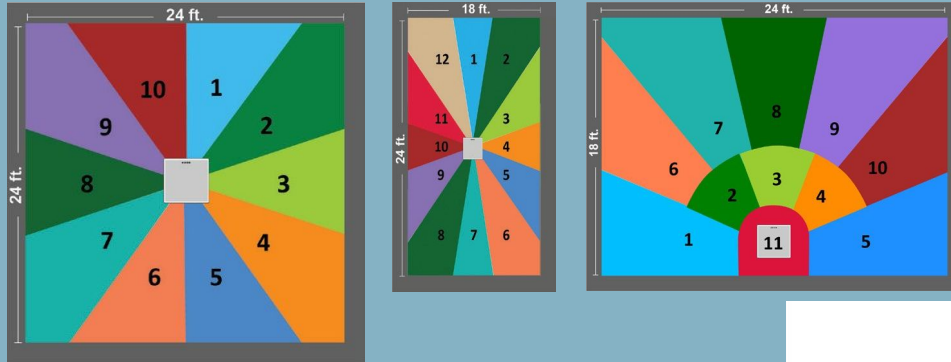

- + Ceiling mounted microphone, both analog and Dante
- + 3 uni-directional microphones with range 70 Hz - 20 kHz in one enclosure
- + Each mic is numbered (I, II, III) - for easy identification
- + LED diods - status On/Mute
- + 100% immune from RF interference
- + Adjustable length of drop-down cable - 0-2.1 meters from ceiling.



The image features a brick wall background with a large, stylized logo for 'ClearOne'. The logo consists of the word 'ClearOne' in a bold, white, sans-serif font with a black outline. The letters are set against a dark, irregular shape that resembles a microphone or a stylized 'C'. The background of the logo is filled with various colors: pink, orange, and grey. There are also some white and blue splatters around the logo, giving it a graffiti-like appearance. A registered trademark symbol (®) is visible at the end of the word 'One'.

ClearOne®

Wireless microphones



- + Receiver (with built-in dipole antenna)
- + Microphones (handheld, belpack, goose-neck, tabletop)
- + Charger (for 4 types of transmitter), but a USB charger will be OK, too.



- Very low latency, high quality digital signal, 256-bit encryption
- 4 or 8 channels in receiver, up to 32 channels in one system
- frequency ranges: 500, 550, 586 MHz,
- Microphones: handheld (condenser, dynamic), tabletop (directional, omnidirectional), goose-neck (15, 30, 45 cm), beltpack.

ClearOne®



www.mikropo.hu